

Section Contents	NADCA No.	Format	Page
<b>Frequently Asked Questions</b>			<b>5-2</b>
<b>1 Introduction</b>			<b>5-2</b>
<b>2 What is GD&amp;T?</b>			<b>5-2</b>
<b>3 Why Should GD&amp;T be Used?</b>			<b>5-2</b>
<b>4 Datum Reference Frame</b>			<b>5-4</b>
4.1 Primary, Secondary, Tertiary Features & Datums			5-4
4.2 Datum Feature Vs. Datum Plane			5-5
4.3 Datum Plane Vs. Datum Axis			5-5
4.4 Datum Target Sizes & Locations			5-6
<b>5 Feature Control Frame</b>			<b>5-6</b>
<b>6 Rule #1 – Taylor Principle (Envelope Principle)</b>			<b>5-7</b>
<b>7 GD&amp;T Symbols/Meanings</b>			<b>5-8</b>
<b>8 Material Conditions</b>			<b>5-8</b>
8.1 Maximum Material Condition (MMC)			5-8
8.2 Least Material Condition (LMC)			5-9
8.3 Regardless of Feature Size (RFS)			5-10
<b>9 Location Tolerances</b>			<b>5-11</b>
9.1 Position Tolerance			5-11
9.2 Concentricity & Symmetry Tolerances			5-13
<b>10 Profile Tolerance</b>			<b>5-14</b>
<b>11 Run Out Tolerances</b>			<b>5-18</b>
<b>12 Orientation Tolerances</b>			<b>5-19</b>
<b>13 Form Tolerances</b>			<b>5-21</b>
13.1 Straightness			5-21
13.2 Flatness			5-23
13.3 Circularity (Roundness)			5-23
13.4 Cylindricity			5-23
<b>14 Conversion Charts</b>			<b>5-29</b>
14.1 Conversion of Position (Cylindrical) Tolerance Zones to/from Coordinate Tolerance Zones			5-29
14.2 Conversion of Position Tolerance Zone to/from Coordinate Tolerance Zone			5-32
14.3 Conversion of Coordinate Measurements to Position Location Measurements			5-33

# Engineering & Design: Geometric Dimensioning

## Frequently Asked Questions (FAQ)

- 1) Is Geometric Dimensioning used on just Die Castings and why should it be used?  
See page 5-2 - Why should GD&T be used?
- 2) What is a Location Tolerance?  
See page 5-11, Location Tolerances
- 3) How do I convert a linear tolerance to true position?  
See pages 5-32 through 5-34, Conversion of Position.
- 4) Is a list of GD&T symbols available?  
See page 5-8, GD&T Symbols and Meanings.
- 5) When can I use Profile of a surface instead of flatness?  
See page 5-14, Profile Tolerances.

## 1 Introduction

The concept of Geometric Dimensioning and Tolerancing (GD&T) was introduced by Stanley Parker from Scotland in the late 1930's. However, it was not used to any degree until World War II (WW II) because until then the vast majority of products were made in-house. The designer could discuss with the manufacturing personnel (die designer, foundry foreman, machinist, and inspectors) what features were to be contacted to establish the so called "centerlines" that were used on the drawing to locate features such as holes and keyways. Also when two (2) or more features were shown coaxial or symmetrical around these "centerlines", the questions that needed to be answered by the designer was, "how concentric or symmetrical do these features have to be to each other?". During WW II companies had to "farm out" parts because of the quantities/schedules. This meant the new manufacturer had to interpret the drawing hence the "centerlines" were often established by contacting features that were not functional or important and features produced from these incorrect "centerlines" were not at the location required. The parts did not assemble and/or did not function properly and had to be fixed or scrapped. GD&T was the solution to this major problem. GD&T provides a designer the tools to have clear, concise, and consistent instructions as to what is required. It eliminates ambiguities so that everyone involved with the part will not have to interpret the dimensioning.

## 2 What is GD&T?

It is compilation of symbols and rules that efficiently describe and control dimensioning & tolerancing for all drawings (castings, machined components, etc.). It is documented in ASME Y14.5M which has the symbols, rules, and simple examples. Also ASME Y14.8 has guidance for casting and forging drawings.

## 3 Why should GD&T be used?

- a. It is a simple and efficient method for describing the tolerancing mandated by the designer of the part.
- b. It eliminates ambiguities as to what Datum features are to be contacted to establish the Datum planes and/or Datum axis that are to be used for locating other features. All inspection will result in the same result – the dimension is within or out of tolerance. Fig. 5-1 illustrates a simple example of ambiguities associated with the "old" type drawing. Fig. 5-2 illustrates the same example with GD&T.
- c. It simplifies inspection because hard gages can often be utilized and inspection fixtures are often mandated which simplifies inspection for production quantities.
- d. It forces the designer to totally consider function, manufacturing process, and inspection methods. The result is larger tolerances that guarantee function, but reduce manufacturing and inspection costs. Also the "bonus" or extra tolerance for certain conditions can result in significant production cost savings. In addition the time to analyze whether a missed dimension is acceptable is dramatically reduced.

# Engineering & Design: Geometric Dimensioning

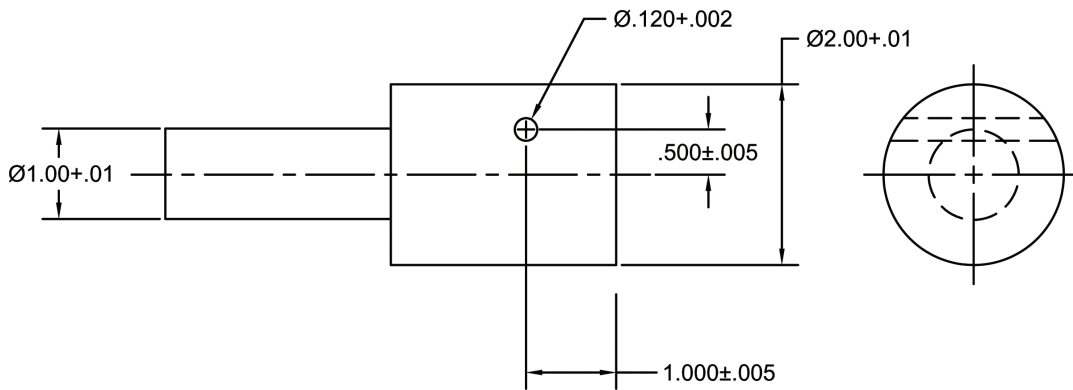

Figure 5-1 "OLD" Drawing without GD&T.

## Questions:

- 1) What is the relationship (coaxiality tolerance) between the  $\text{Ø}1.00$  and the  $\text{Ø}2.00$ ?
- 2) Which feature ( $\text{Ø}1.00$  or  $\text{Ø}2.00$ ) is to be used for measuring (locating) the  $.500 \pm .005$  dimension for locating the  $\text{Ø}.120$  hole?

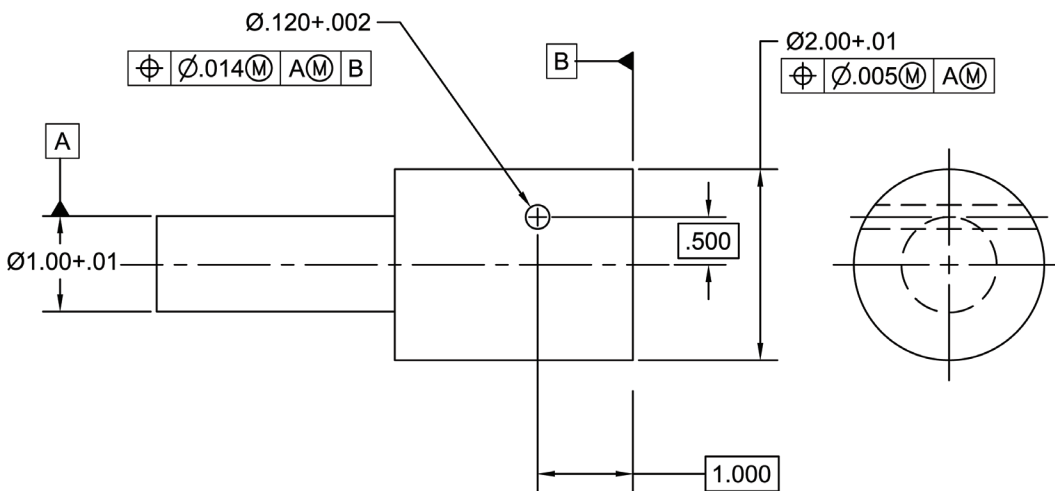

Figure 5-2 "NEW" Drawing with GD&T.

## Questions asked in Fig. 5-1 answered:

- 1) The axis of the  $\text{Ø}2.00$  has to be coaxial with the axis of the  $\text{Ø}1.00$  within a tolerance zone that is a  $\text{Ø}0.005$  if the  $\text{Ø}$  is 2.01 which is the Maximum Material Condition (MMC).
- 2) The  $\text{Ø}1.00$  is the feature to be used for measuring the  $.500$  dimension for locating the  $\text{Ø}.120$  hole. The tolerance for locating the  $\text{Ø}.120$  hole is a  $\text{Ø}$  of  $.014$  (the diagonal of the rectangular tolerance zone shown in Fig. 5-1) when the hole is a MMC ( $\text{Ø}.120$ ).

## 4 Datum Reference Frame (DRF)

The DRF is probably the most important concept of GD&T. In order to manufacture and/or inspect a part to a drawing, the three (3) plane concept is necessary. Three (3) mutually perpendicular (exactly  $90^\circ$  to each other) and perfect planes need to be created to measure from. In GD&T this is called Datum Reference Frame whereas in mathematics it is the Cartesian coordinate system invented by Rene Descartes in France (1596-1650). Often one would express this concept as the need to establish the X,Y, and Z coordinates. The DRF is created by so-called Datum Simulators which are the manufacturing, processing, and inspection equipment such as surface plate, a collet, a three jaw chuck, a gage pin, etc. The DRF simulators provide the origin of dimensional relationships. They contact the features (named Datum Features) which of course are not perfect hence measurements from simulators (which are nearly perfect) provides accurate values and they stabilize the part so that when the manufacturer inspects the part and the customer inspects the part they both get the same answer. Also if the part is contacted during the initial manufacturing setup in the same manner as when it is inspected, a “layout” for assuring machining stock is not required. The final result (assuming the processing equipment is suitable for the tolerancing specified) will be positive.

### 4.1 Primary, Secondary, and Tertiary Features & Datums

The primary is the first feature contacted (minimum contact at 3 points), the secondary feature is the second feature contacted (minimum contact at 2 points), and the tertiary is the third feature contacted (minimum contact at 1 point). Contacting the three (3) datum features simultaneously establishes the three (3) mutually perpendicular datum planes or the datum reference frame. If the part has a circular feature that is identified as the primary datum feature then as discussed later a datum axis is obtained which allows two (2) mutually perpendicular planes to intersect the axis which will be the primary and secondary datum planes. Another feature is needed (tertiary) to be contacted in order orientate (fix the two planes that intersect the datum axis) and to establish the datum reference frame. Datum features have to be specified in an order of precedence to properly position a part on the Datum Reference Frame. The desired order of precedence is obtained by entering the appropriate datum feature letter from left to right in the Feature Control Frame (FCF) (see Section 5 for explanation for FCF). The first letter is the primary datum, the second letter is the secondary datum, and the third letter is the tertiary datum. The letter identifies the datum feature that is to be contacted however the letter in the FCF is the datum plane or axis of the datum simulators. Note that there can be multiple datum sets used to reference different features on the casting. See Fig. 5-3 for Datum Features & Planes.

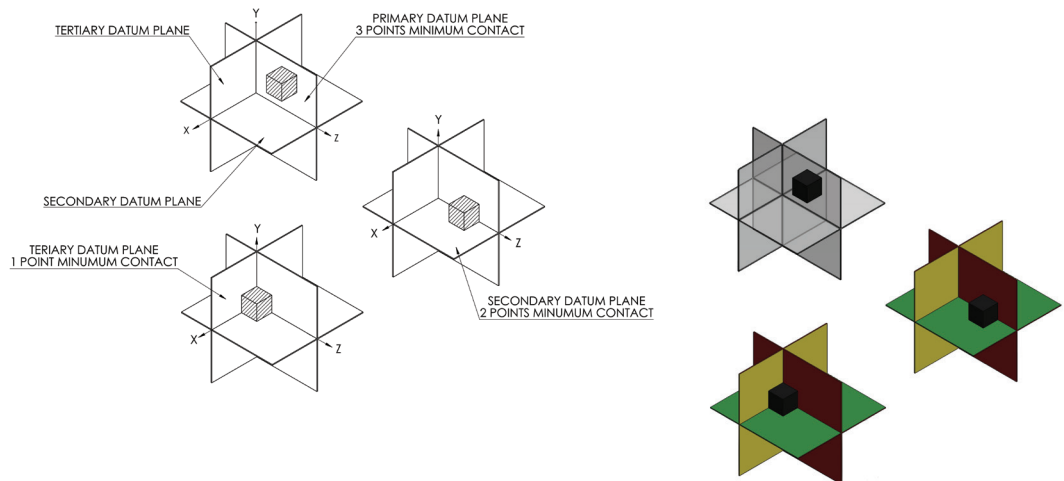

Figure 5-3 Primary, secondary, tertiary features & datum planes.

## 4.2 Datum Feature vs Datum Plane

The datum features are the features (surfaces) on the part that will be contacted by the datum simulators. The symbol is a capital letter (except I, O, and Q) in a box such as  $\boxed{A}$  used in the 1994 ASME Y14.5 or  $\boxed{A}$  used on drawings made to the Y14.5 before 1994. The features are selected for datums based on their relationship to toleranced features, i.e., function, however they must be accessible, discernible, and of sufficient size to be useful. A datum plane is a datum simulator such as a surface plate. See Fig. 5-4 for a Datum Feature vs a Datum Plane.

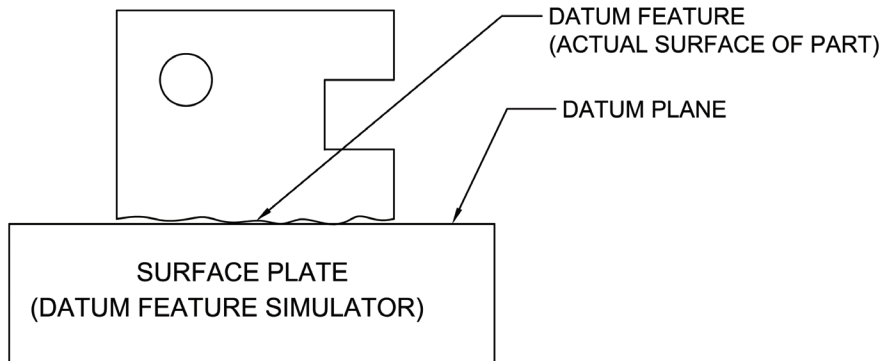

Figure 5-4 Datum feature vs. datum plane.

## 4.3 Datum Plane vs Datum Axis

A datum plane is the datum simulator such as a surface plate. A datum axis is also the axis of a datum simulator such as a three (3) jaw chuck or an expandable collet (adjustable gage). It is important to note that two (2) mutually perpendicular planes can intersect a datum axis however there are an infinite number of planes that can intersect this axis (straight line). Only one (1) set of mutually perpendicular planes have to be established in order to stabilize the part (everyone has to get the same answer – does the part meet the drawing requirements?) therefore a feature that will orientate or “clock” or “stabilize” has to be contacted. The datum planes and datum axis establish the datum reference frame and are where measurements are made from. See Fig. 5-5 for Datum Feature vs Datum Axis.

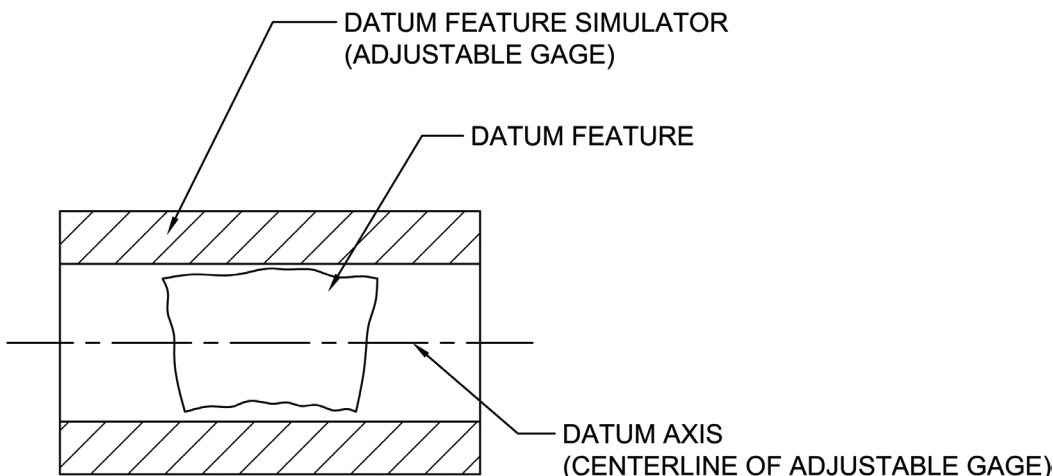
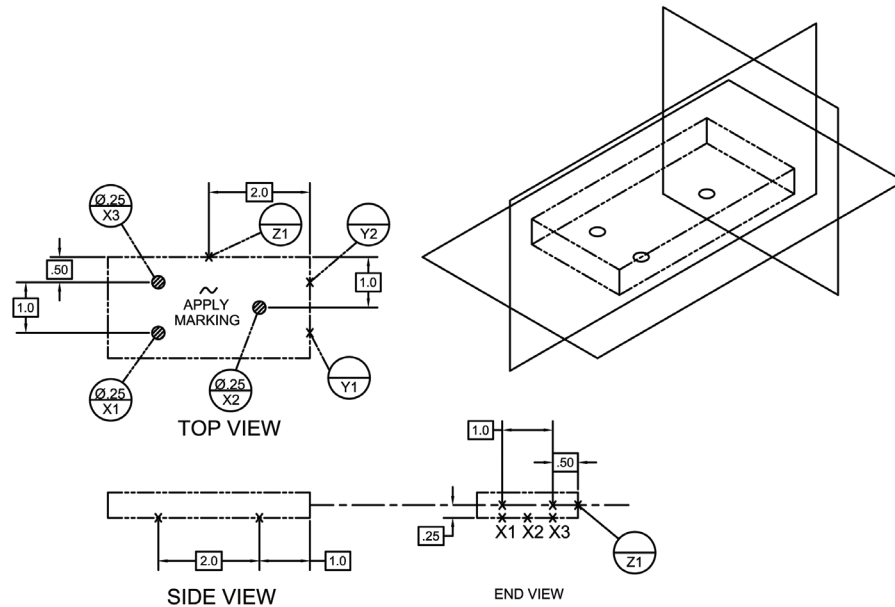

Figure 5-5 Datum feature vs. datum axis.

## 4.4 Datum Target Sizes & Locations

Datum targets are datum simulators such as spherical pins or round flat bottom pins or three (3) jaw chucks or centers that establish datum planes or a datum axis. They contact the datum features and are often specified to be used for inspecting parts that are inherently not round or straight or flat or they are large parts. If targets are not used then the entire datum feature has to contact a datum simulator. An example of what can result is the part could “rock” on a surface plate if the part was not relatively flat which would result in an unstable scenario and conflicting results. If the datum feature is large a datum simulator that contacts the entire feature may not exist or would be extremely expensive to produce. The datum targets are the datum planes and datum axis and often are assembled together to create an inspection fixture and or a manufacturing fixture. See Fig. 5-6 for Datum Target Sizes & Locations.



Component configuration shown as phantom lines on separate drawing

- Illustrates orientation when targets contact component
- Illustrates that targets are physically separate from the component
- Apply marking is shown to depict which side is to be contacted by the targets

Figure 5-6 Target sizes & locations.

## 5 Feature Control Frame

The geometric tolerance for an individual feature is specified in the Feature Control Frame which is divided into compartments – see Fig 5-7. The first compartment contains the type of geometric characteristic such as true position, profile, orientation, etc. The second compartment contains the tolerance (where applicable the tolerance is preceded by a diameter symbol and followed by a material condition symbol). The remaining compartments contain the datum planes or axis in the proper sequence (primary datum is the first letter).

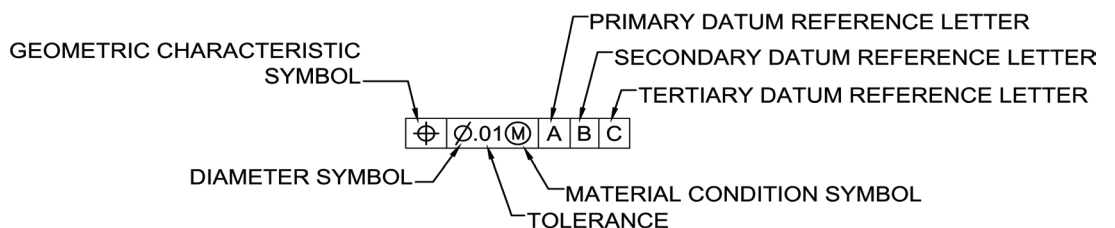

Figure 5-7 Feature control frame.

## 6 Rule # 1 – Taylor Principle (Envelope Principle)

When only a size tolerance is specified for an individual feature of size the form of this feature shall not extend beyond a boundary (envelope) of perfect form at maximum material condition (MMC). In other words, when the size is at MMC the feature has to be perfectly straight. If the actual size is less than the MMC the variation in form allowed is equal to the difference between the MMC and the actual size. The relationship between individual features is not controlled by size limits. Features shown perpendicular, coaxial or symmetrical to each other must be controlled for location or orientation otherwise the drawing is incomplete. In other words Fig. 5-1 is an incomplete drawing. Fig. 5-8 shows the meaning of Rule #1 for an external cylinder (pin or shaft) and an internal cylinder (hole). Note that a hard gage can be used to inspect this principle or requirement.

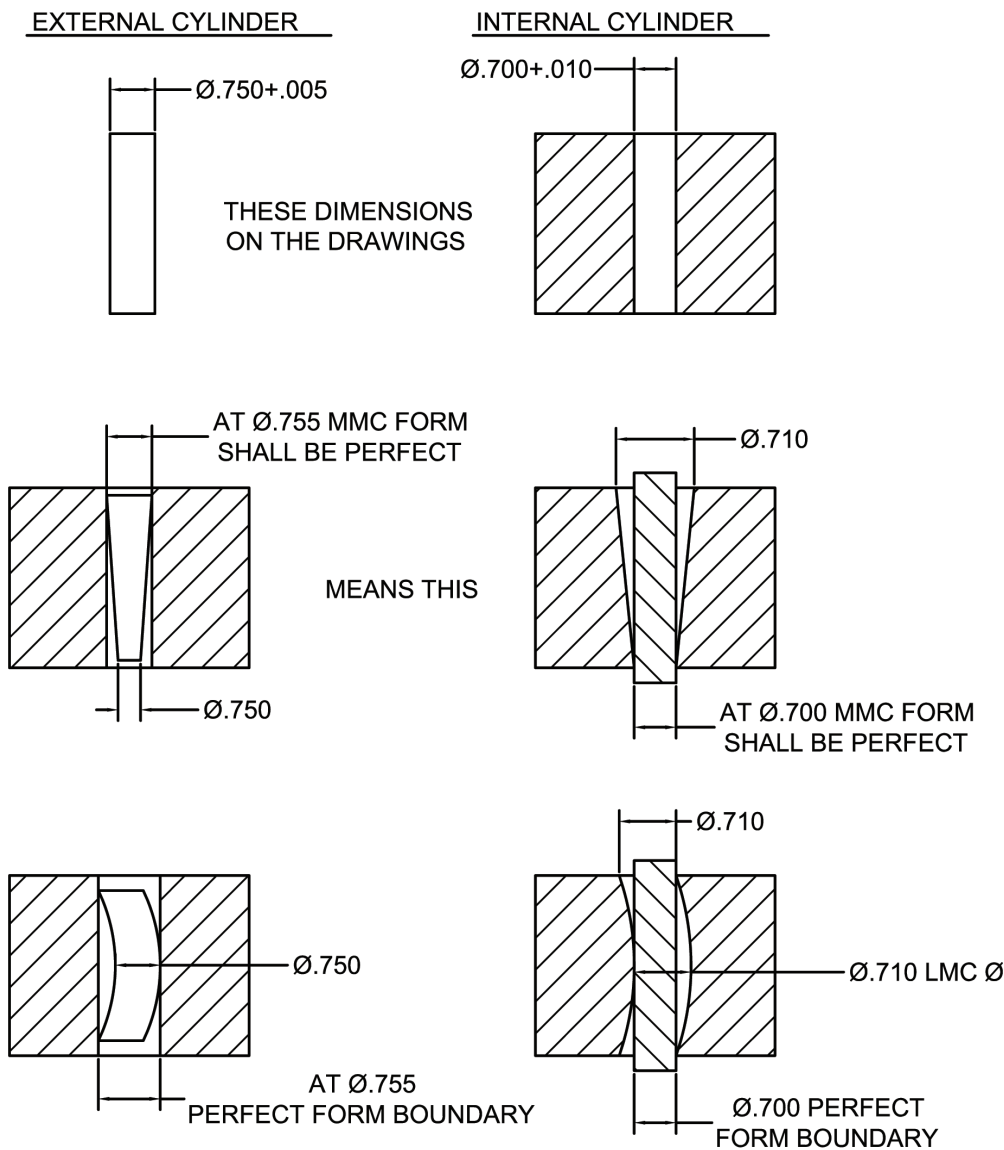

Figure 5-8 Rule #1.

# Engineering & Design: Geometric Dimensioning

## 7 GD&T Symbols / Meanings

Tolerance Type	Geometric Characteristics	Symbol	Applied To		Datum Reference Required	Use $\text{\textcircled{L}}$ or $\text{\textcircled{M}}$ Material Condition	Gages Used
			Feature Surface	Feature of Size Dim.			
Form	Straightness	—	YES	YES	NO	YES	YES***
	Flatness	$\square$		NO		NO	
	Circularity	$\circ$					
	Cylindricity	$\text{\textcircled{C}}$					
Location	Positional Tolerance	$\text{\textcircled{P}}$	NO	YES	YES	YES	YES***
	Concentricity	$\text{\textcircled{C}}$				NO	NO
	Symmetry	$\text{\textcircled{S}}$					
Orientation	Perpendicularity	$\perp$	YES	YES	YES	YES	YES***
	Parallelism	$\parallel$					
	Angularity	$\sphericalangle$					
Profile	Profile of a Surface	$\text{\textcircled{P}}$	YES	NO	YES*	YES**	NO
	Profile of a Line	$\text{\textcircled{L}}$					
Runout	Circular Runout	$\nearrow$	YES	YES	YES	NO	NO
	Total Runout	$\text{\textcircled{R}}$					

\* Can be used to control form without a datum reference.

\*\* Datum reference only.

\*\*\* – Yes if  $\text{\textcircled{M}}$  is specified for the feature of size being controlled

– No if  $\text{\textcircled{S}}$  or  $\text{\textcircled{L}}$  are specified for the feature of size being controlled.

## 8 Material Conditions

Features of size which includes datum features have size tolerances hence the size condition or material (amount of metal) condition can vary from the maximum metal condition (MMC) to the least metal condition (LMC). Consequently if the center planes or axes of a feature of size are controlled by geometric tolerances a modifying symbol can be specified in the feature control frame that applies the tolerance value at either the maximum or the least material condition. It also can be specified for a datum that is a feature of size. If a symbol is not specified the tolerance value applies regardless of material condition which is named regardless of feature size (RFS).

### 8.1 Maximum Material Condition (MMC)

This is the condition when the actual mating size or envelope size is at the maximum material condition which is maximum size for an external feature such as a cylinder and the minimum size for an internal feature such as a hole. Another way to look at MMC is that it always allows components to be assembled. The symbol is  $\text{\textcircled{M}}$ . The tolerance value specified for the feature being controlled in the FCF applies only if the actual mating envelope is the MMC size. If the actual mating envelope deviates from MMC an additional tolerance is allowed. The added tolerance is the difference between the actual mating envelope size and the MMC size hence the largest actual mating envelope named virtual condition is equal to the MMC size plus the tolerance specified in the FCF for an external feature and minus for an internal feature. The MMC symbol is used to assure that parts will assemble and it allows the use of so called hard gages (go gages) for quick inspections. An example of position with MMC is shown in Fig. 5-9. It should be noted that actual local size has to meet the size tolerance however the actual local size does not affect the geometric characteristic tolerance.



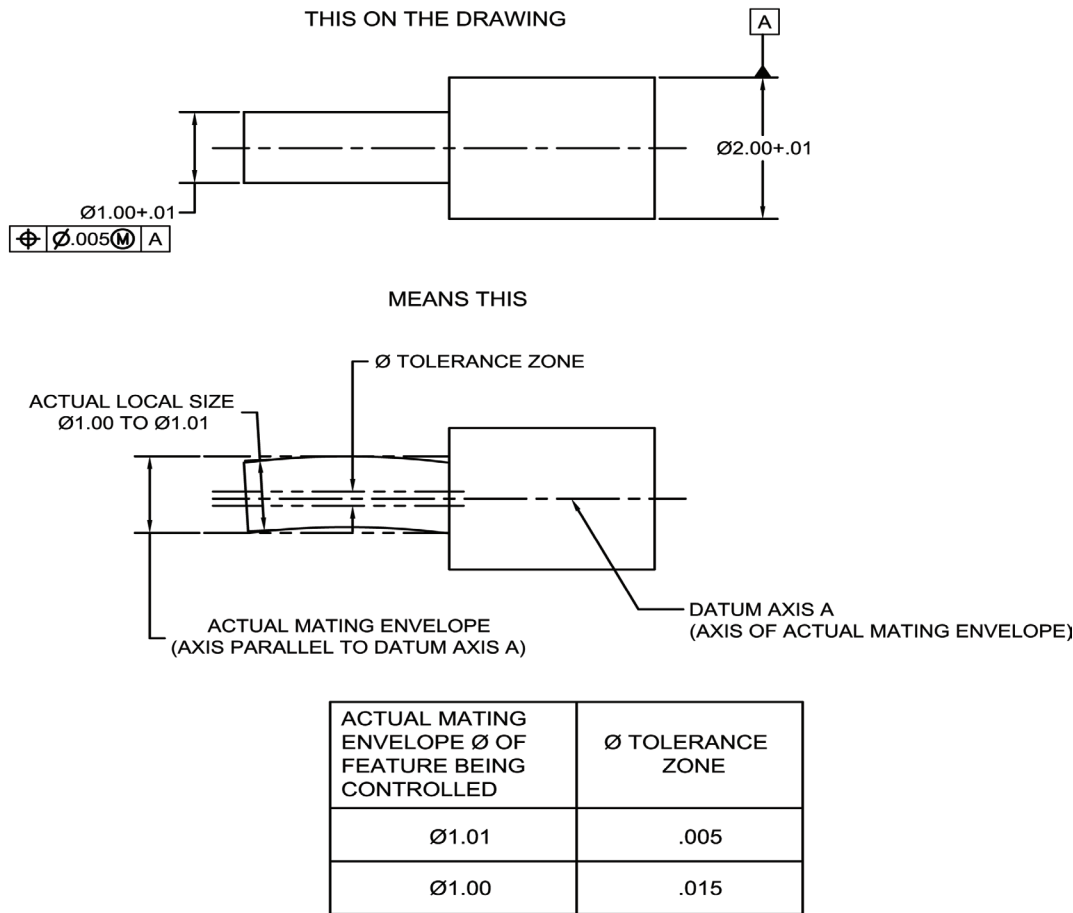

Figure 5-9 Position control with MMC.

## 8.2 Least Material Condition (LMC)

This is the opposite of MMC consequently this is the condition when the actual minimum mating size or envelope is at the minimum material condition which is minimum size for an external feature such as a cylinder and the maximum size for an internal feature such as a hole. Another way to look at LMC is that it always prevents components from being assembled. The symbol is  $\text{Ⓛ}$ . Additional tolerance is allowed if the actual minimum envelope deviates from LMC and is the difference between the actual mating size and the LMC size hence the smallest actual mating size is equal to the LMC size minus the tolerance specified in the FCF for an external feature and plus for an internal feature. The LMC symbol is used to assure a minimum amount of machining stock for features that are to be machined and for assuring a minimum amount of wall thickness between external and internal features. Hard gages cannot be used for inspection. An example of position with LMS is shown in Fig. 5-10. It should be noted that the actual local size has to meet the size tolerance however the local size does not affect the geometric characteristic tolerance.

# Engineering & Design: Geometric Dimensioning

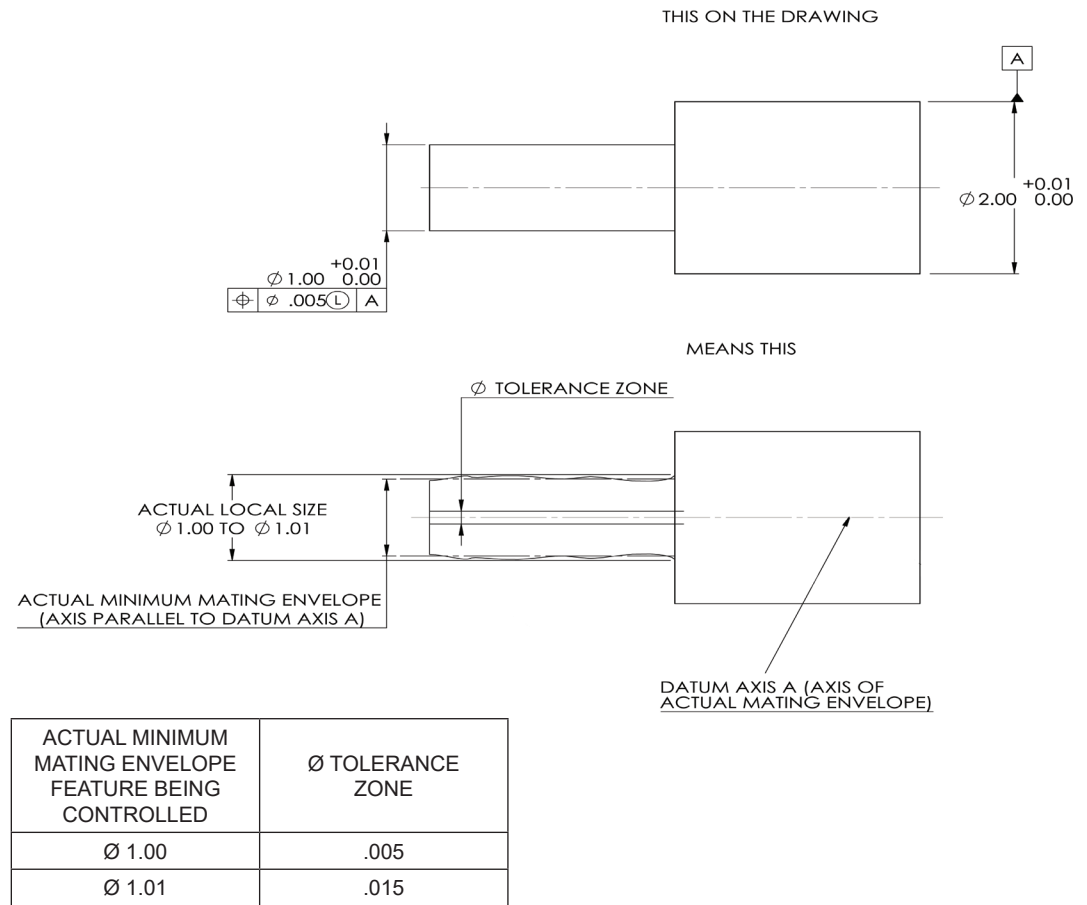
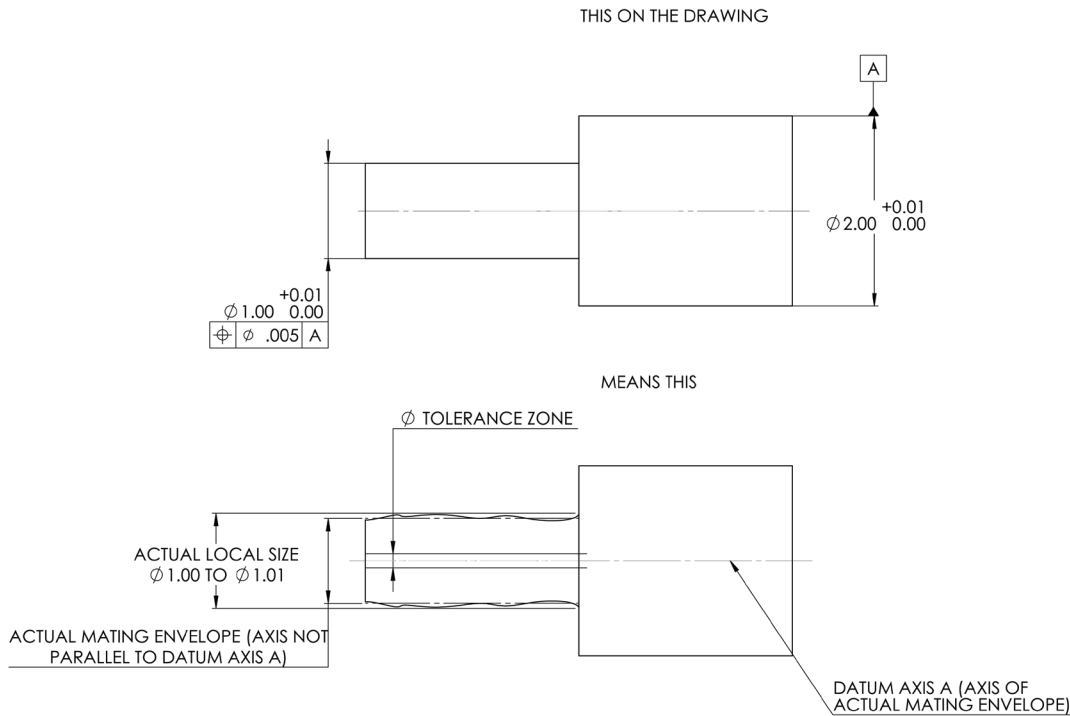

Figure 5-10 Position control with LHC.

## 8.3 Regardless of Feature Size (RFS)

There is no symbol in the 1994 Y14.5 whereas it was  $\textcircled{S}$  for the 1982 Y14.5. It is applicable if the MMC or the LMC are not specified for individual features of size tolerances or for datum features of size. The tolerance is limited to the specified value in the FCF and if applied to a datum feature of size the actual axis or center plane have to be established regardless of the feature size. It is always used for run out, concentricity, and symmetry controls as will be discussed in those sections. It is also used when targets are specified to establish datum axes and center planes because the targets have to contact the datum features to be useful. Also it is used to control wall thickness variation between external and internal features. Hard gages are not applicable since there is no additional or bonus tolerance as allowed for MMC and LMC. An example of position with RFS is shown in Fig. 5-11.



ACTUAL MINIMUM MATING ENVELOPE FEATURE BEING CONTROLLED	Ø TOLERANCE ZONE
Ø 1.00	.005
Ø 1.01	.005

Figure 5-11 Position control with RFS.

## 9 Location Tolerances

These include position, concentricity, and symmetry tolerances. Position is used to control coaxiality of features, the center distance between features, and the location of features as a group. Concentricity and symmetry are used to control the center distance of feature elements. These three (3) tolerances are associated with datum's because the obvious question is – located from what?

### 9.1 Position Tolerance

Positional tolerances are probably used more than any other geometric control. It is used to locate features of size from datum planes such as a hole or keyway and used to locate features coaxial to a datum axis. The tolerance defines a zone that the axis or center plane of a feature of size may vary from. The concept is there is an exact or true position that the feature would be if it was made perfect however since nothing is made perfect a tolerance zone allows deviation from perfection. The exact location of a feature of size is defined by basic dimensions which is shown in a box (□) and are established from datum planes or axes. Coaxial controls are typically a cylindri-

# Engineering & Design: Geometric Dimensioning

cal tolerance zone which has a diameter value and the true position is a datum axis. A positional control is indicated by the position symbol ( $\varnothing$ ), a tolerance value (diameter symbol precedes the tolerance value if desired), the applicable material condition modifier ( $\text{M}$  or  $\text{L}$ ) if desired, and the appropriate datum references placed in a feature control frame. When a material condition modifier is specified a boundary named virtual condition is established. It is located at the true position and it may not be violated by the surface or surfaces of the considered feature. Its size is determined by adding or subtracting depending on whether the feature is an external or an internal feature and whether the material condition specified is  $\text{M}$  or  $\text{L}$ . An example for controlling the location of holes is shown in Fig. 5-12 and of a keyway in Fig. 5-13.

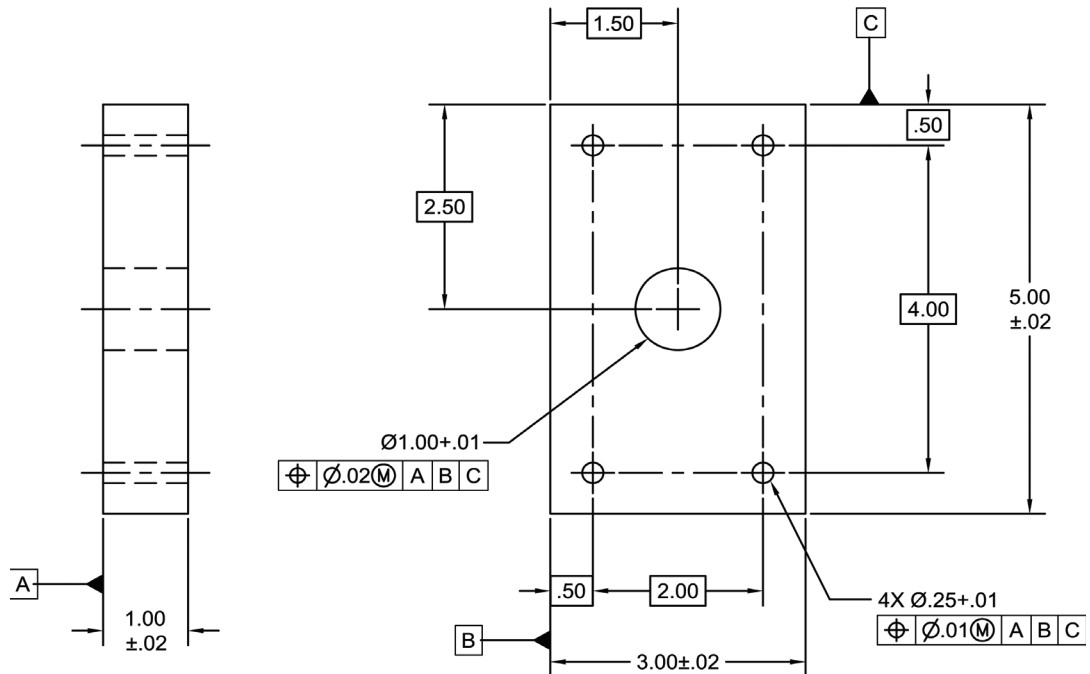

Figure 5-12 Positional tolerancing of holes.

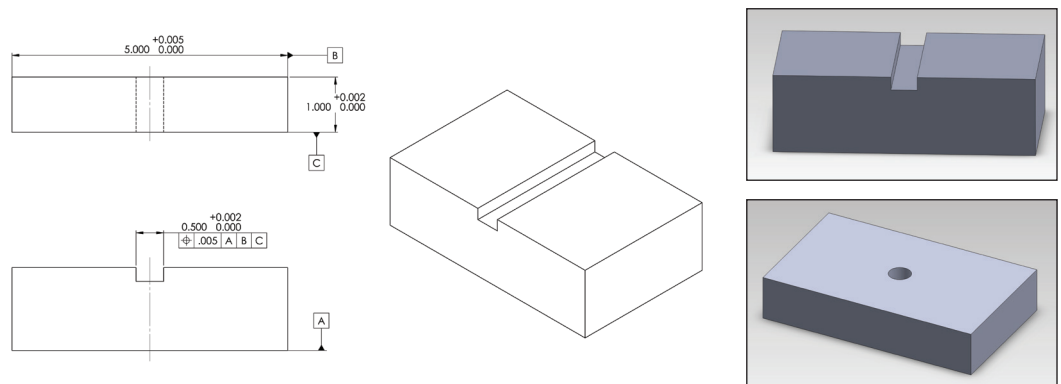

Figure 5-13 Positional tolerance for keyway.

**Notes:**

- 1) Datum B is the feature of size (5.000+.005) hence the true position for the keyway is the midplane of datum B.
- 2) No material condition modifier specified for either the keyway location tolerance .005 or the datum B, hence the material condition is 'regardless of feature size' for both features.

## 9.2 Concentricity & Symmetry Tolerances

These both control the median points of a feature of size: concentricity (◎) is applied to circular features (often where the part or nearby parts are rotating) whereas symmetry ( $\equiv$ ) is applied to non circular features. Both require that the median points of the controlled feature, regardless of its size, to be within the tolerance zone (cylindrical zone for concentricity and two parallel planes for symmetry). The tolerance zone is equally disposed about the datum axis for concentricity and datum plane for symmetry. These controls are not used very often because median points are difficult to establish due to irregularities of form and the only reason to use these controls is for controlling the out of balance that can exist if the mass center is not close to the axis of rotation or center plane. Examples of controlling concentricity and symmetry are shown in Fig. 5-14 & 5-15 respectively.

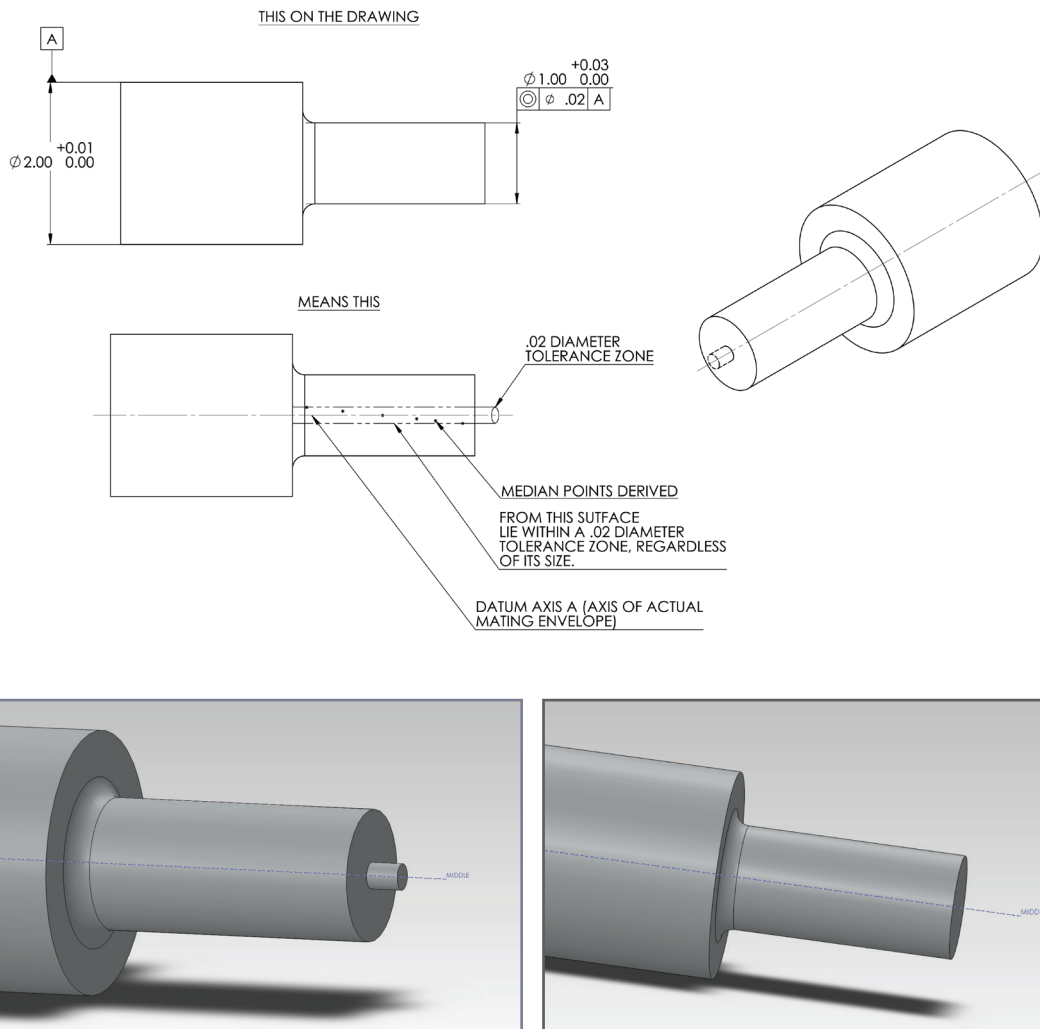

# Engineering & Design: Geometric Dimensioning

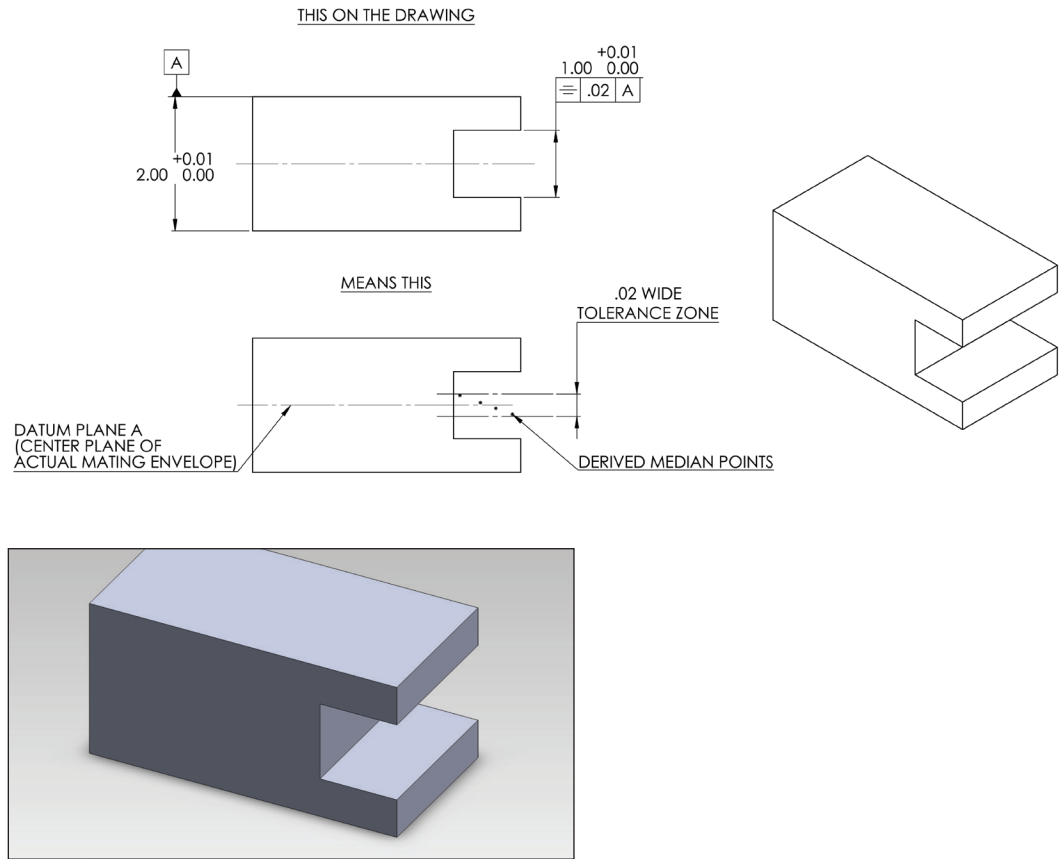

Figure 5-15 Symmetry tolerancing.

## 10 Profile Tolerances

Profile tolerances can control the location, orientation, and form of a feature that has no size (surface). There are two (2) types – profile of a surface ( $\square$ ) and profile of a line ( $\circ$ ). The exact or true profile of a feature is established by basic dimensions of radii, angular dimensions, and coordinate dimensions established from datums however a profile tolerance can be specified to an individual surface without specifying a datum – see Fig. 16. The elements of a profile (outline of an object in a given plane) are straight lines or arcs. The tolerance is a boundary of two (2) parallel planes disposed (equally – see Fig. 17 or in one direction – see Fig. 16) and normal (perpendicular) along the perfect or true profile within which the entire surface must lie. The profile can be controlled between two (2) points – see Fig. 16. Also if datum planes are established by targets – see Fig. 18 the tolerance zone is equally disposed about the datum planes whereas if the datum planes are established by complete contact with the datum features the tolerance zone is unidirectional and  $\frac{1}{2}$  the tolerance value in the FCF – see Fig. 17 vs Fig. 18.

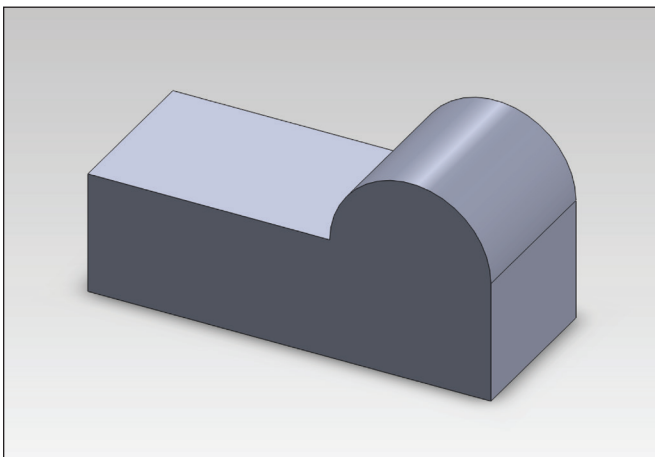
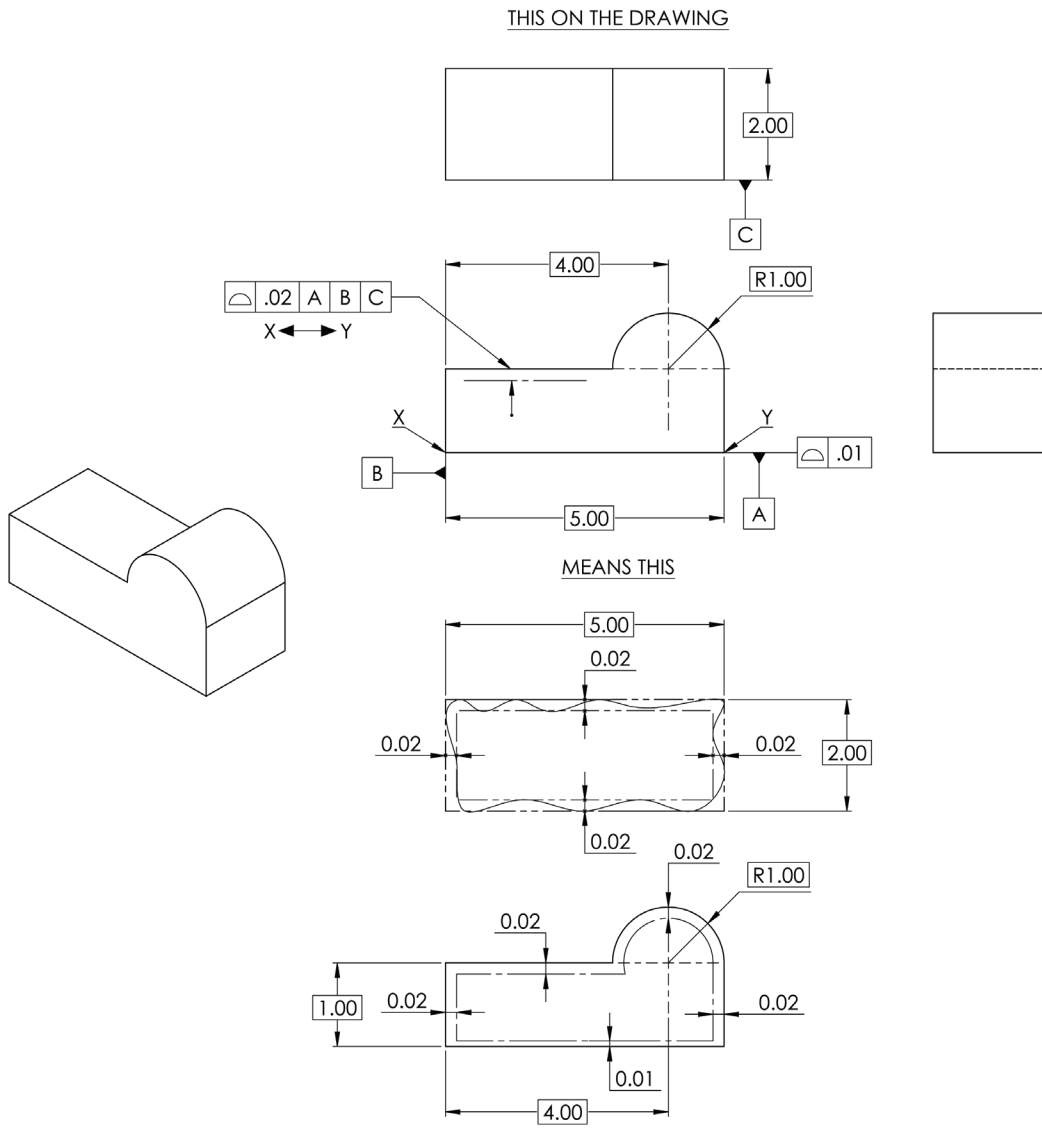
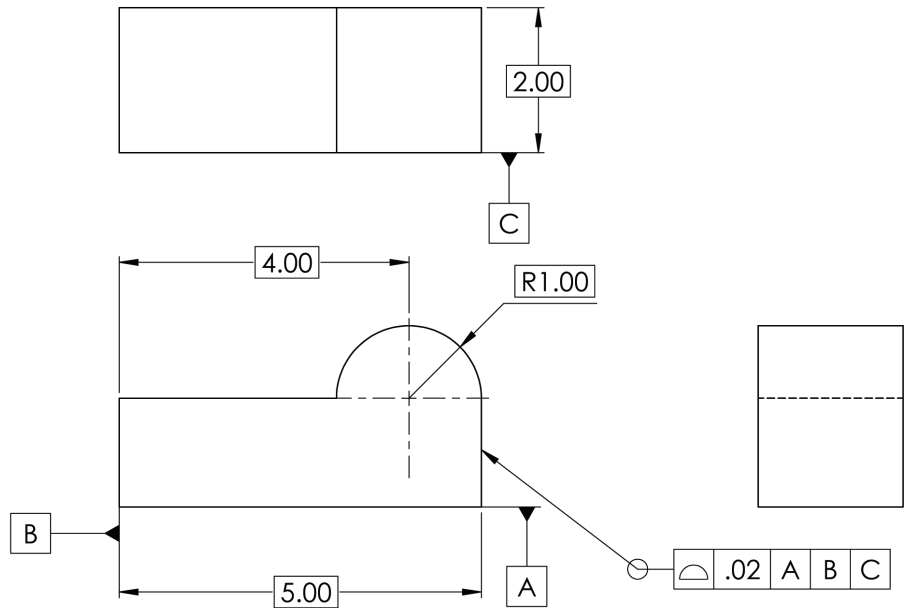

Figure 5-16 Profile control – unidirectional and between points.

# Engineering & Design: Geometric Dimensioning

THIS ON THE DRAWING



MEANS THIS

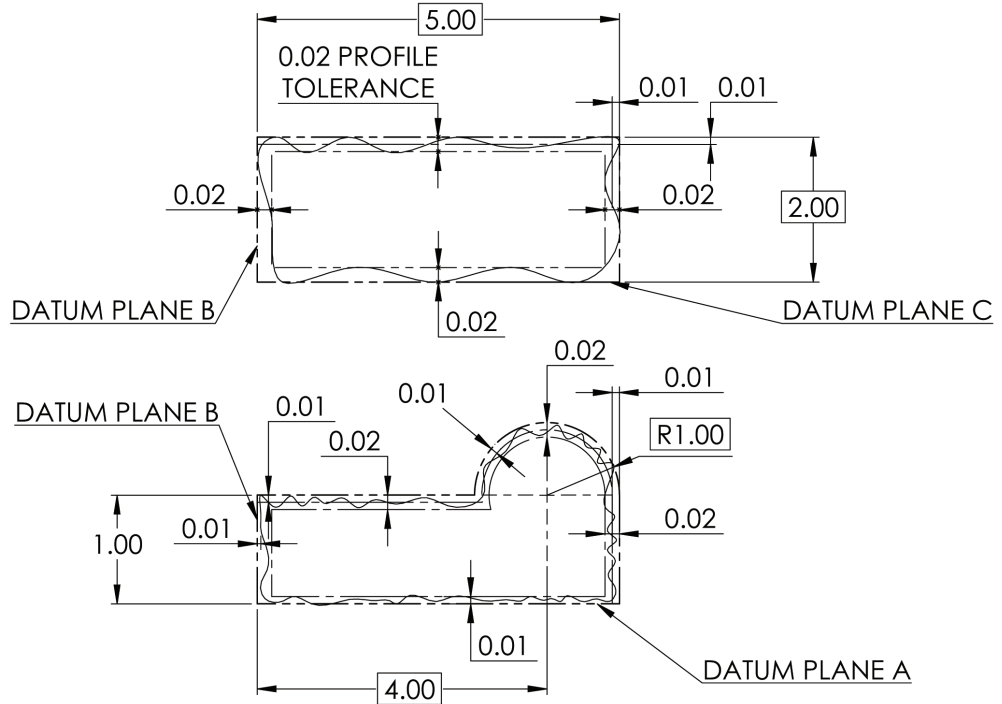

**Notes:**

- 1) All surfaces to be within  $.02 \pm .01$  tolerance zone of true or perfect profile.
- 2) Datum  $\boxed{A}$   $\boxed{B}$  and  $\boxed{C}$  to be within .01 of datum planes A, B, and C.

Figure 5-17 Profile control – all around entire part without targets.



# Engineering & Design: Geometric Dimensioning

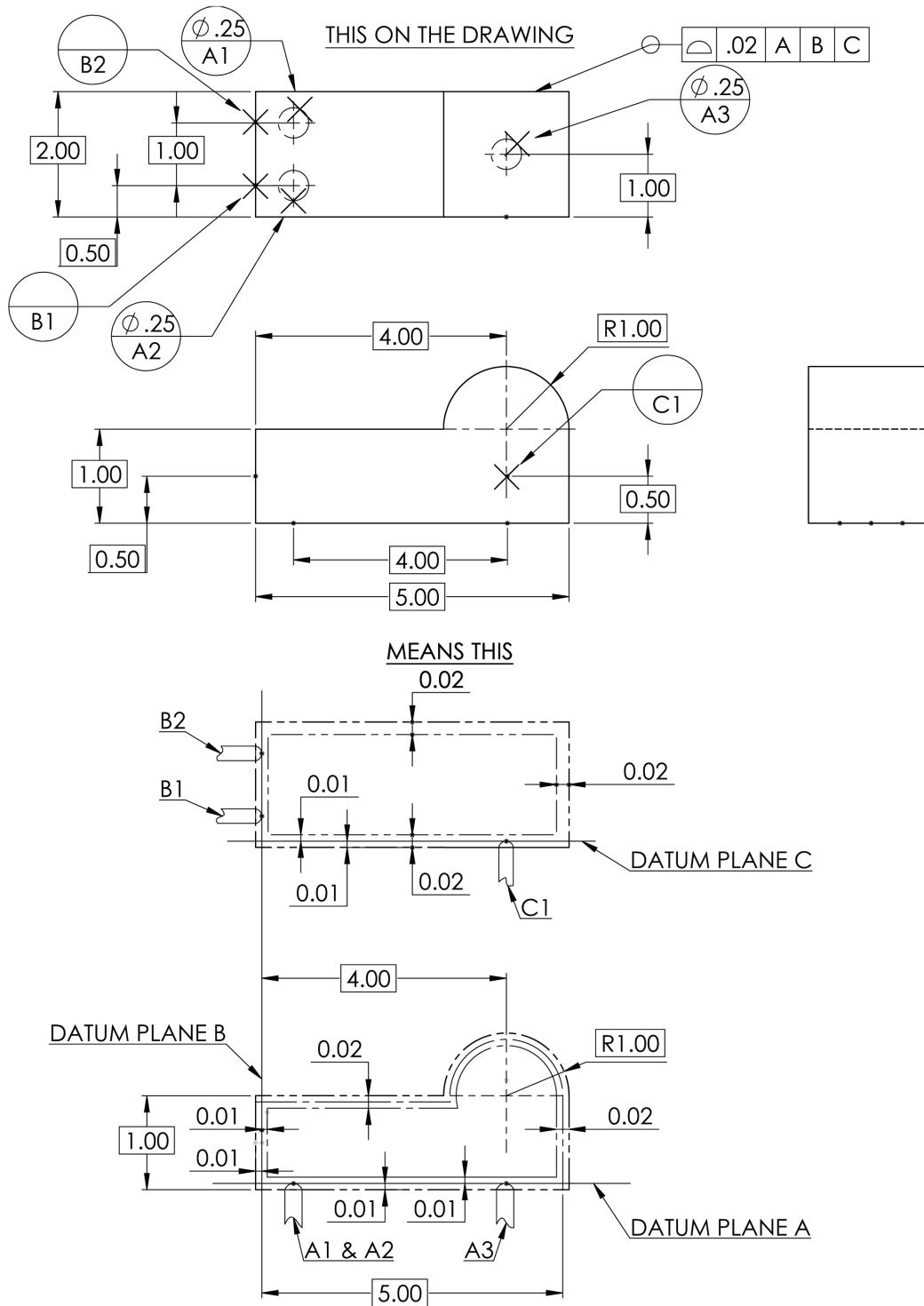

Figure 5-18 Profile control – all around entire part with targets.

# Engineering & Design: Geometric Dimensioning

## 11 Run Out Tolerances

Run out tolerances control the relationship of a feature relative to a datum axis established from one (1) diameter or two (2) diameters separated axially – see Fig. 5-19. The material condition applied to the feature being controlled and the datum feature or features is always RFS because 360° rotation is required to conduct the inspection. If targets are not specified to establish the datum axis the entire datum feature has to be contacted which may not be practical. There are two (2) types of run out controls – circular ( $\nearrow$ ) and total ( $\blacktriangleleft\blacktriangleright$ ). Circular run out controls the cumulative variation of circularity (roundness) and coaxiality for features constructed around a datum axis and circular elements of a surface constructed an angle not parallel to the datum axis (control wobble). The tolerance is the full indicator movement (FIM) for each circular element independently as the part is rotated 360°. For each measurement the dial indicator is removed from the part after each 360° rotation and reset at a new location. Total run out controls the entire surface simultaneously hence it controls cumulative variations in circularity, coaxiality, straightness, taper, angularity, and profile of a surface. The dial indicator is not removed from the part after each 360° rotation. If applied to surfaces that are at an angle to the datum axis it controls variation in angularity (wobble) and flatness (concavity or convexity). See Fig. 5-19 for circular run out and Fig. 5-20 for total run out.

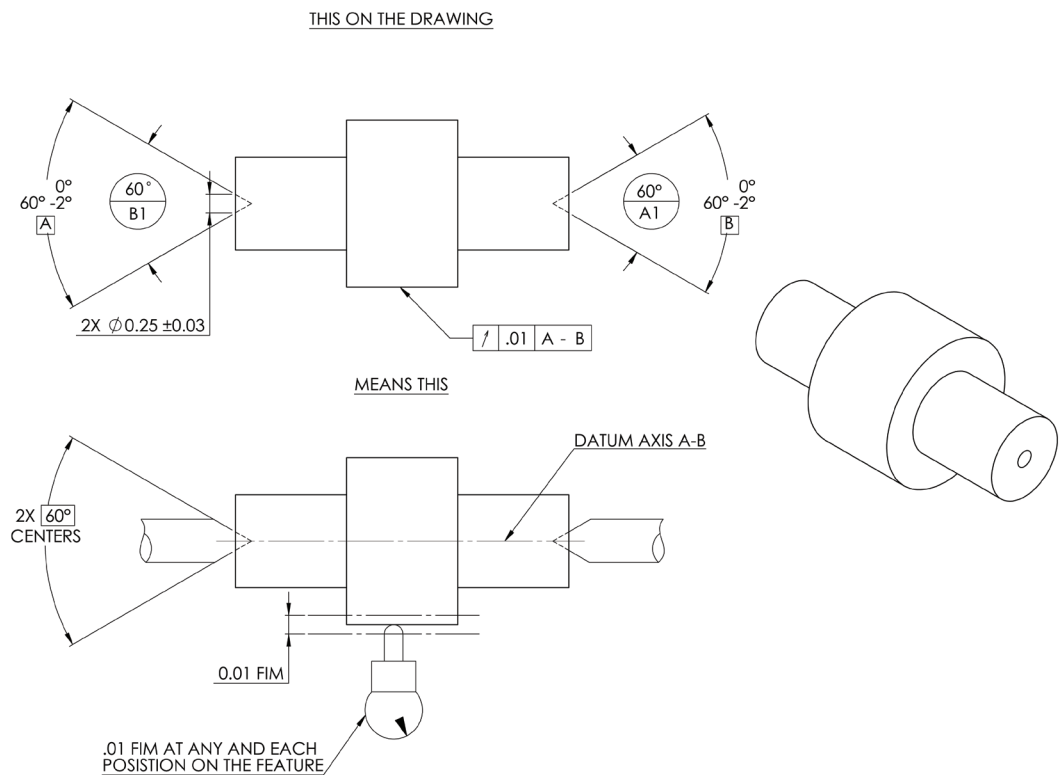

Figure 5-19 Circular runout with targets.

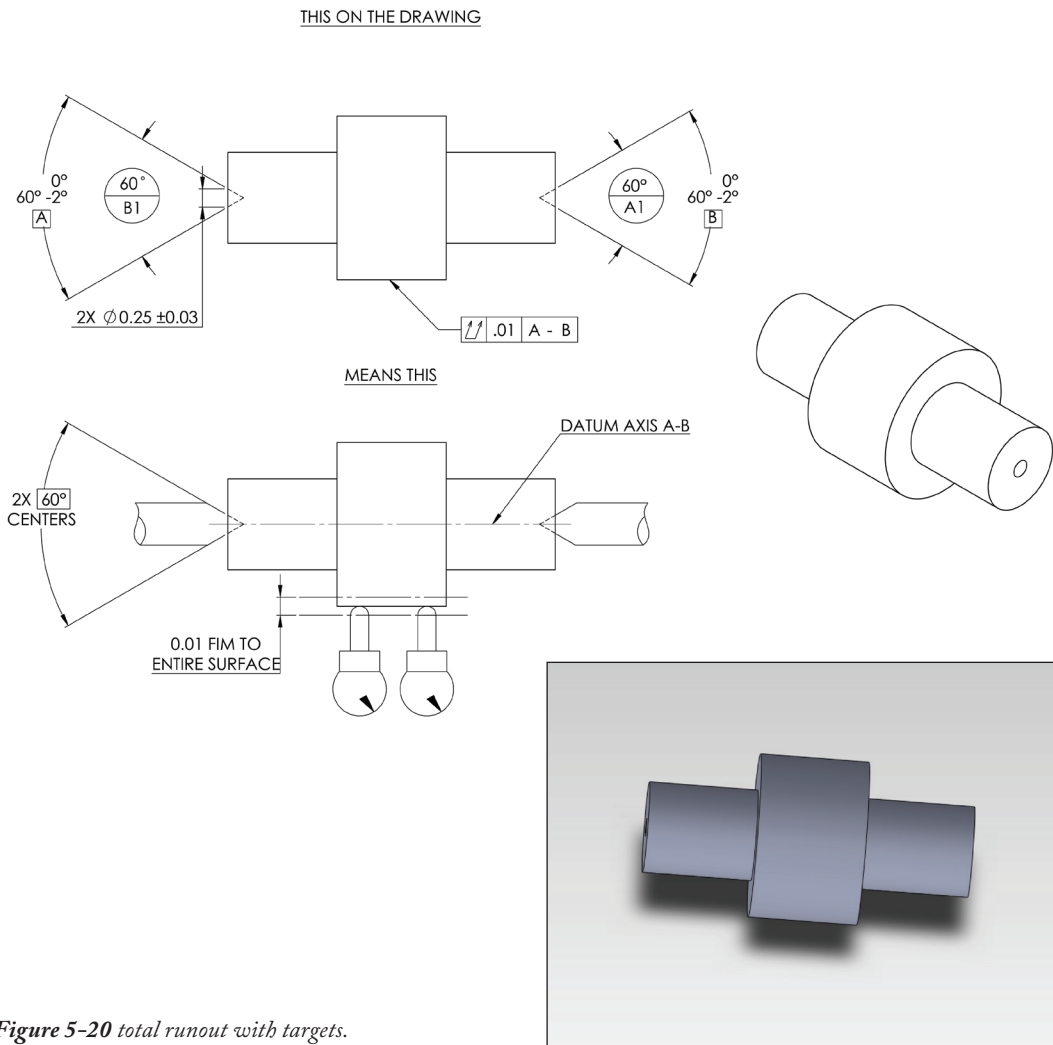

Figure 5-20 total runout with targets.

## 12 Orientation Tolerances

There are three (3) separate orientation tolerances however two (2) of the three are specific values of the general tolerance named angularity. The two (2) specific tolerances are named perpendicularity ( $90^\circ$  to a datum) and parallelism ( $180^\circ$  to a datum). These tolerances control the orientation of features to a datum plane or axis. Angularity controls a surface (non feature of size), a center plane or an axis of a feature of size to a specified angle and its symbol is  $\angle$ . Perpendicularity symbol is  $\perp$  and parallelism symbol is  $\parallel$  and they do the same as angularity except the angles are specific as previously stated. The tolerance zone may be either two (2) parallel planes at the specified basic angle from a datum plane or axis within which the surface, center plane or axis must lie or it may be a cylindrical zone within which the axis of the considered feature must lie. Of course if angularity tolerance is specified for a feature of size the material condition modifiers  $\text{M}$  or  $\text{L}$  may be specified. If neither  $\text{M}$  or  $\text{L}$  is specified then as always the regardless of feature size (RFS) is applicable. See Fig's 5-21 thru 5-23 for examples of  $\angle$ ,  $\perp$ , and  $\parallel$ .

# Engineering & Design: Geometric Dimensioning

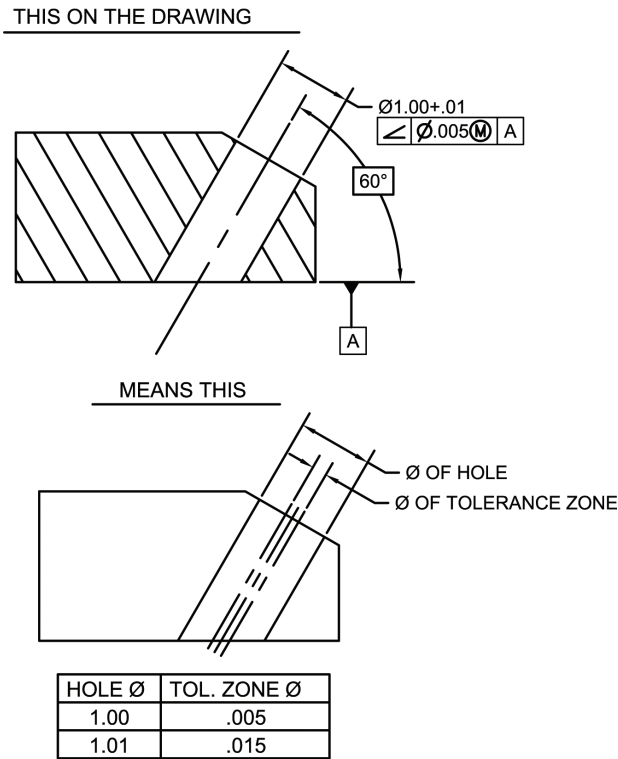

Figure 5-21 Angularity of a feature of size axis at MMC.

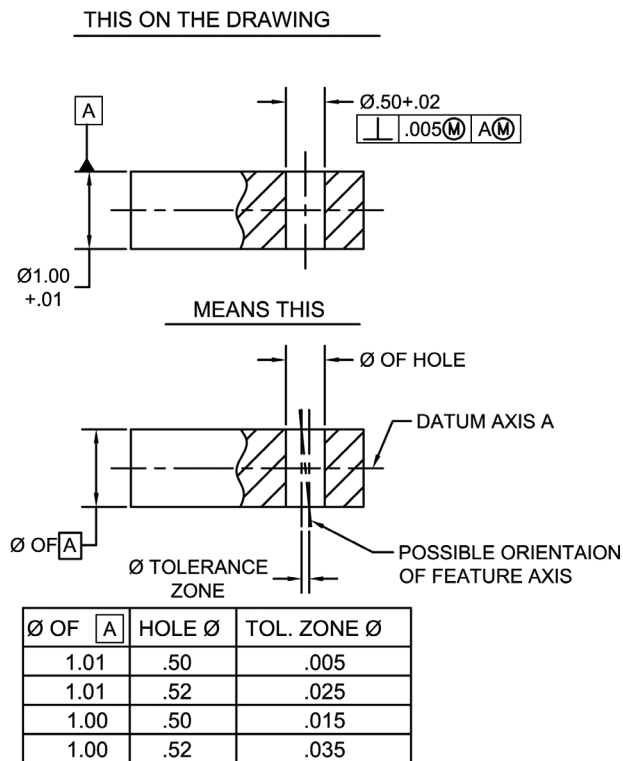

Figure 5-22 Perpendicularity of a feature of size axis at MMC with datum feature of size at MMC.

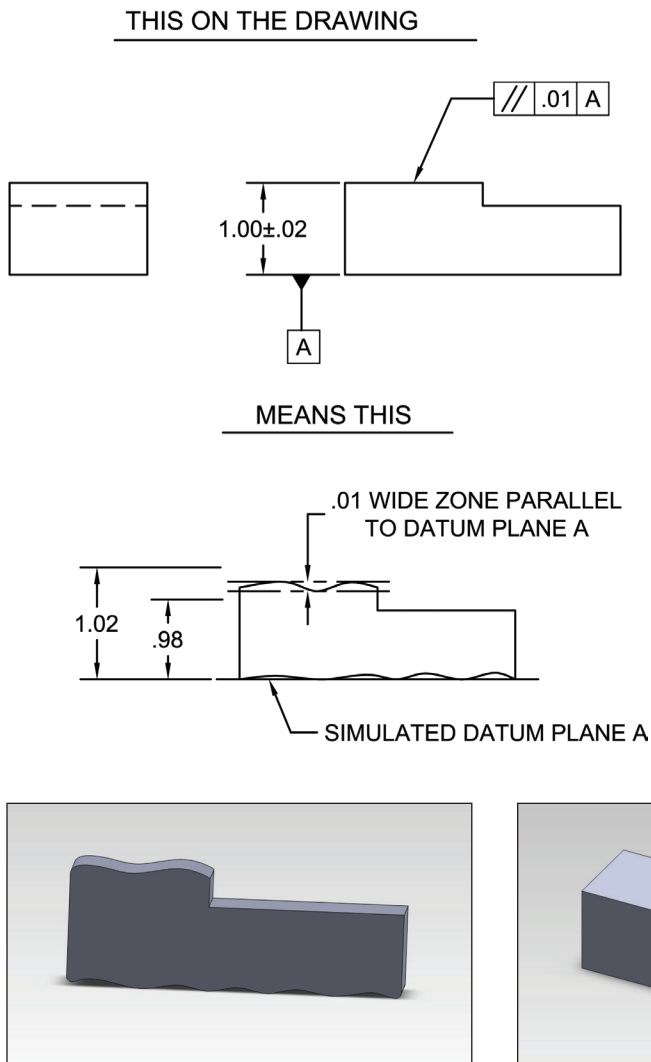

Figure 5-23 Parallelism – surface.

## 13 Form Tolerances

There are four (4) form tolerances : straightness, flatness, circularity, and cylindricity. They apply to individual features therefore the tolerances are not related to datums. Straightness can be used to control the straightness of median line of a feature of size hence material condition modifiers can be applied. The other form tolerances control surfaces hence material condition modifiers are not applicable.

### 13.1 Straightness

There is one symbol (—) for straightness but there are two (2) kinds of controls that are very different from each other. One control is for line elements of surfaces (FCF attached to the surface) and the other is control of an axis or median plane of feature of sizes (FCF attached to the size tolerance). The axis or median plane control relaxes the form control provided by Rule #1 because a perfect form boundary at MMC can be violated if the  $\text{M}$  symbol is specified. Fig. 5-24 illustrates control of line straightness and Fig's 5-25 & 5-26 illustrate control of axis and median plane straightness respectively. The surface straightness tolerance is only for line elements in the view that the FCF is attached.

# Engineering & Design: Geometric Dimensioning

THIS ON THE DRAWING

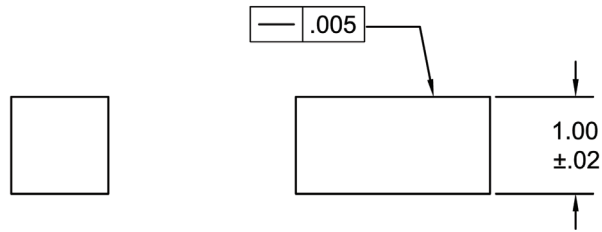

MEANS THIS

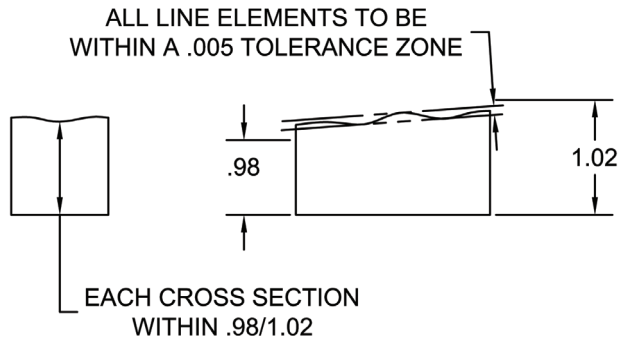
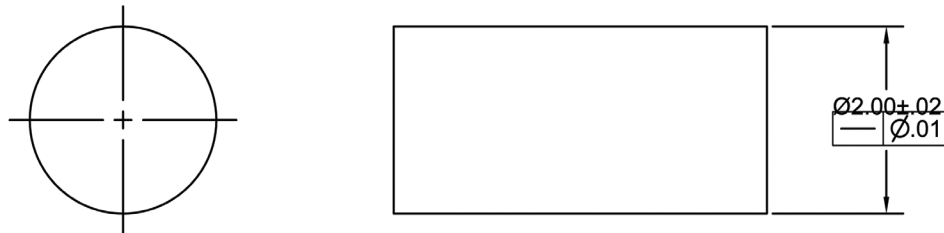

Figure 5-24 Straightness of a surface.

THIS ON THE DRAWING



MEANS THIS

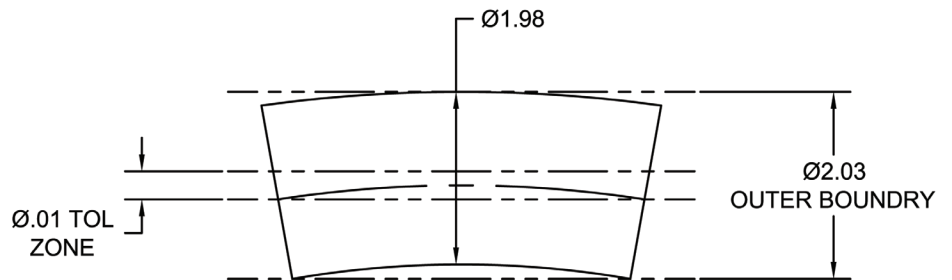

Figure 5-25 Straightness of an axis RFS.

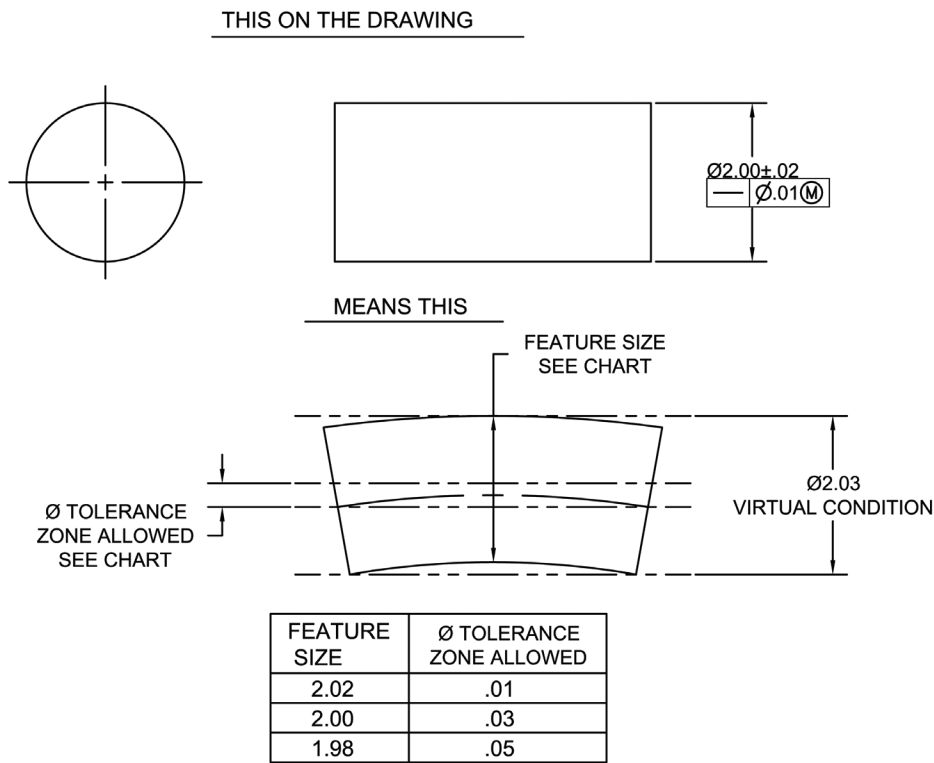

Figure 5-26 Straightness of an axis at MMC.

## 13.2 Flatness

Flatness controls the distance between the high and low points of a surface. The tolerance zone is the distance between two parallel planes that have no particular orientation. All elements of the entire surface must lie between these two planes. See Fig. 5-27 for an illustration of flatness control. The symbol is  $\nabla$ . Flatness is the same as straightness of a surface except straightness controls line elements only in the view that the control is applied whereas flatness controls the entire surface, i.e., all views.

## 13.3 Circularity (Roundness)

Circularity controls each circular element of a cylinder independent of each other. The circular elements of the surface in a plane perpendicular to an axis must lie between two concentric circles whose radii differ by the tolerance value in the FCF. The symbol is  $\bigcirc$ . See Fig. 5-28 for an illustration.

## 13.4 Cylindricity

Cylindricity controls the entire surface of a cylinder. The tolerance zone is two (2) concentric cylinders parallel to the axis of the actual mating envelope. The radii of the concentric cylinders differ by the tolerance value specified in the FCF. It is a composite tolerance that controls circularity, straightness, and taper. The symbol is  $\text{⊂}$ . See Fig. 5-29 for an illustration.

# Engineering & Design: Geometric Dimensioning

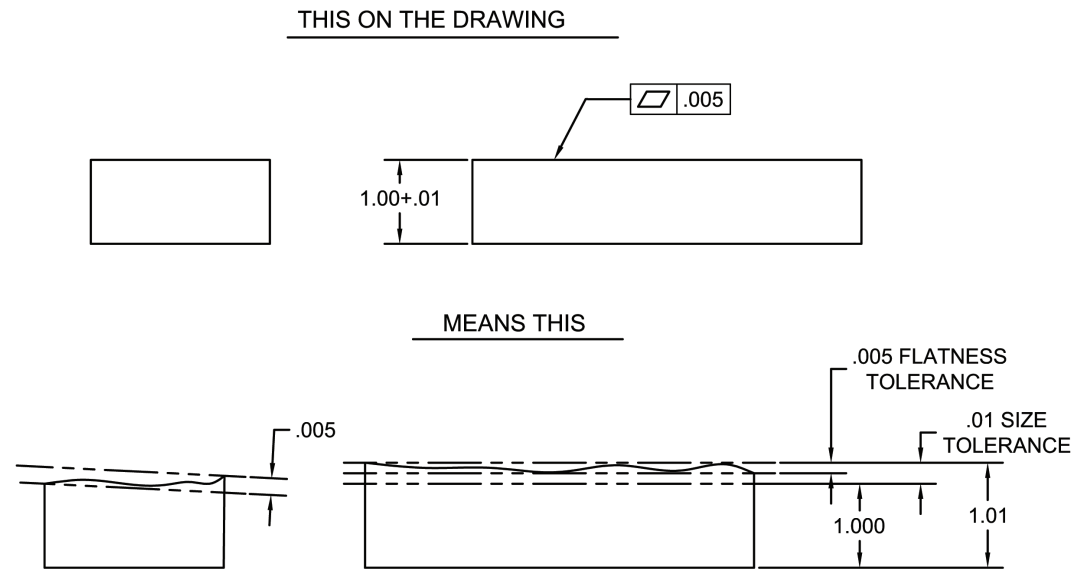
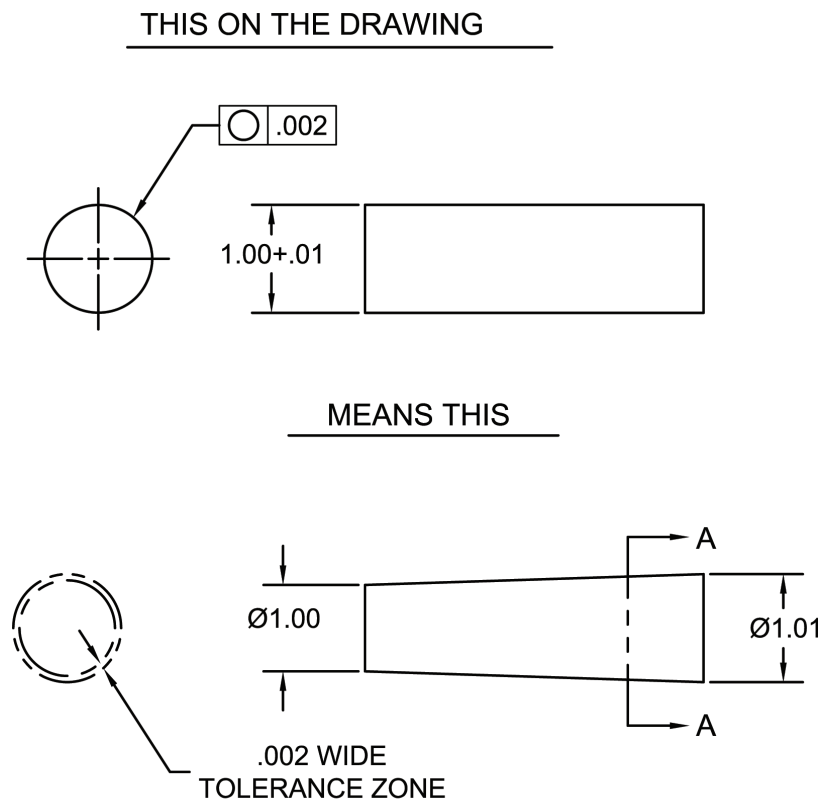

Figure 5-27 Straightness of an axis at MMC.



**Notes:**

Each circular element in a plane perpendicular to an axis must be between two concentric circles with radii that differ by .002. Also each element must be within the size limits.

Figure 5-28 Circularity.



# Engineering & Design: Geometric Dimensioning

THIS ON THE DRAWING

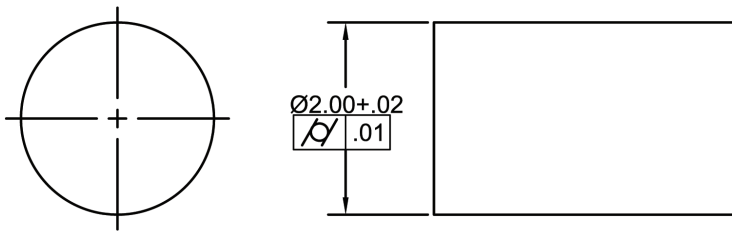

MEANS THIS

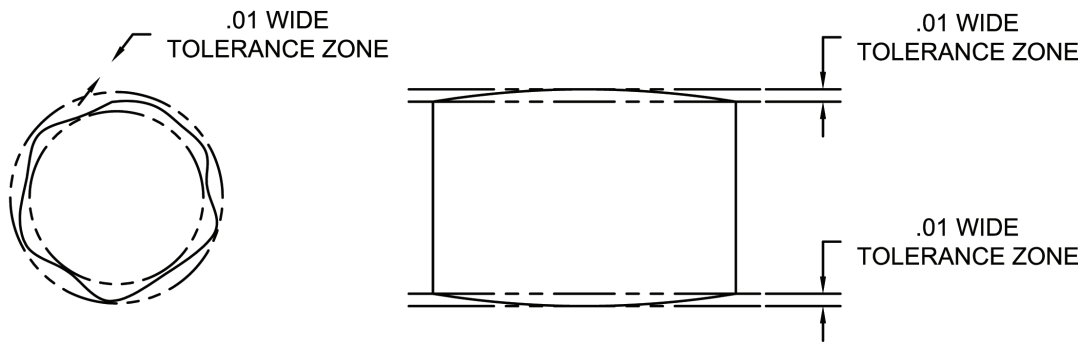

**Notes:**

*Cylindrical surface has to lie between two concentric cylinders with radii that differ by .01. Also the surface must be within the specified size tolerance.*

*Figure 5-29 Cylindricity.*

# Engineering & Design: Geometric Dimensioning

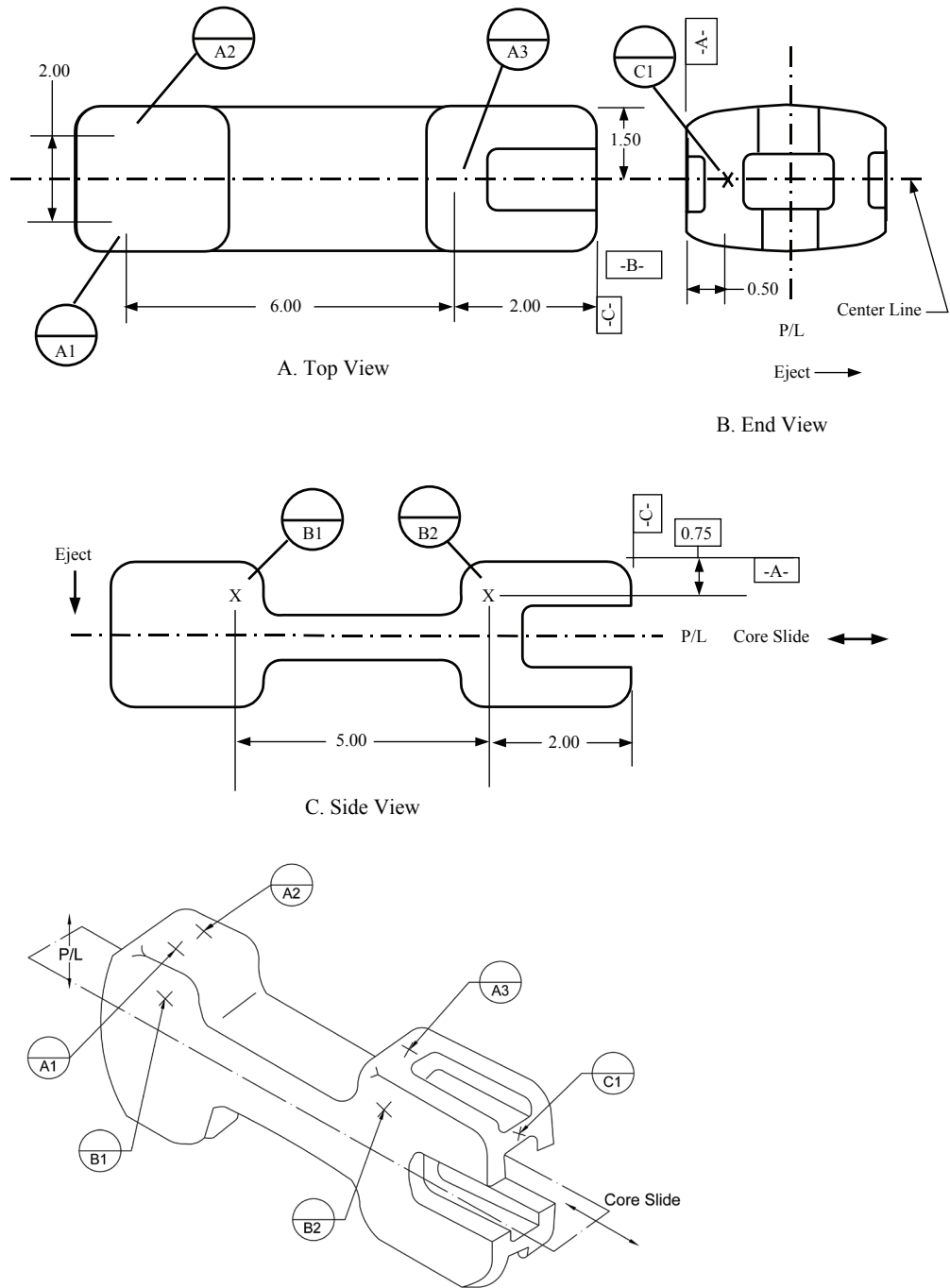
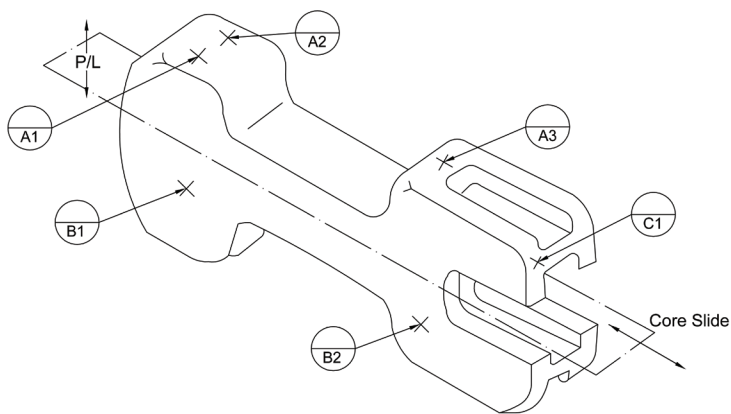
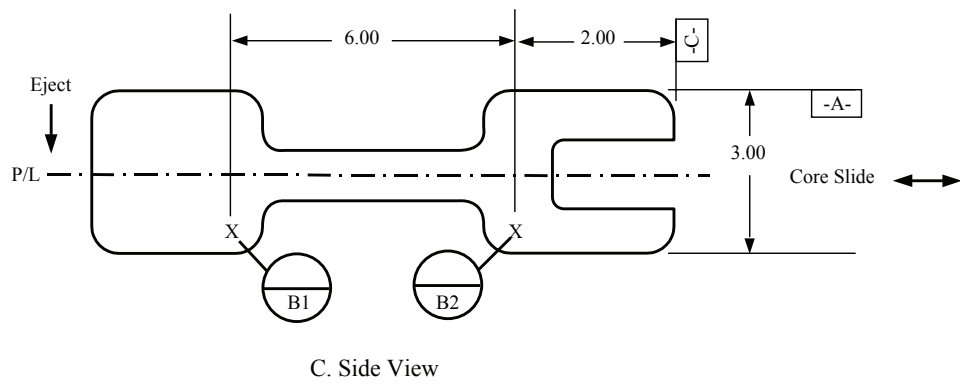
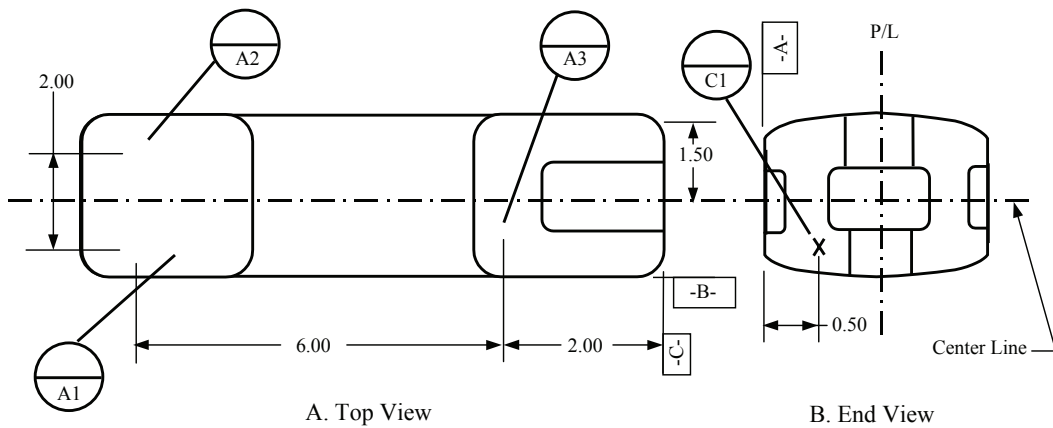

Figure 5-30 Example of an optimal datum reference framework for a die cast part design (all datums on same side of p/l).

# Engineering & Design: Geometric Dimensioning



**Figure 5-31** Example of a less desirable datum reference framework for a die cast part design (datums across p/l). May require additional qualification of some datums.

# Engineering & Design: Geometric Dimensioning

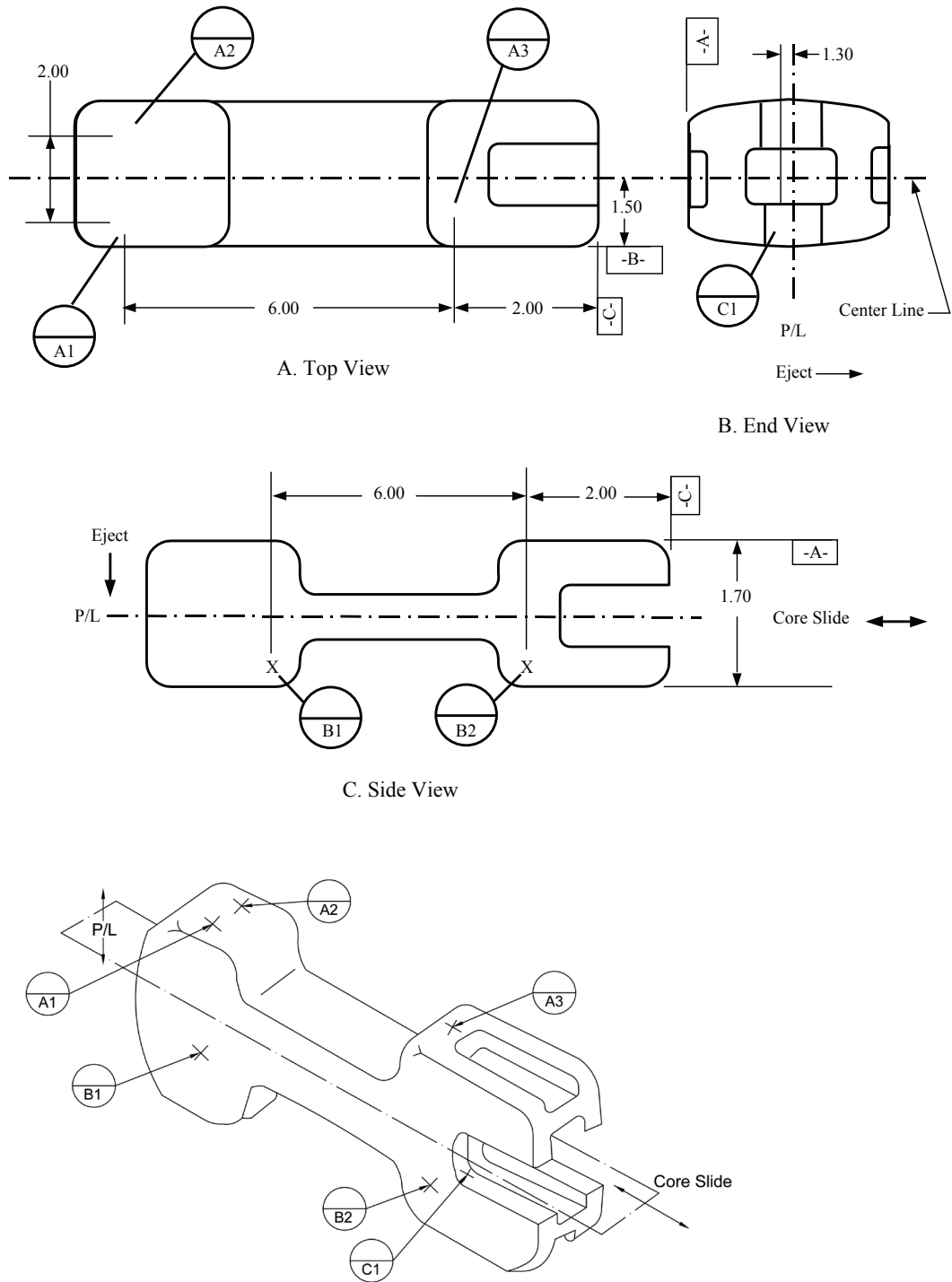

*Figure 5-32 Example of a least preferred datum reference framework for a die cast part design (datums across p/l and datum on moving component). Will require qualification of all datums.*

## 14 Conversion Charts

Coordinate dimensioning defines parts by their location on a three-dimensional grid, utilizing the X-Y-Z coordinate system as in Fig. 5-2. Since the Coordinate Dimensioning System may not consider part function when defining dimensions and tolerances, GD&T is a preferred method of defining and dimensioning parts based on functional relationships to other parts and part features. Sometimes it is necessary for dimensions and tolerances to be converted from one system to the other. Geometric dimensioning and tolerancing is steadily replacing coordinate dimensioning as more emphasis is placed on “designing for manufacturing” early in the product design stage. This section will demonstrate how to convert between coordinate dimensioning and geometric dimensioning.

### 14.1 Conversion of Position (Cylindrical) Tolerance Zones to/from Coordinate Tolerance Zones

When converting total position (cylindrical) tolerance zones to total coordinate tolerance zones, a general rule of thumb is that total coordinate zone is approximately 70% of total position tolerance zone. This is only useful for non-critical applications. For example, for a non-critical part to be converted from position (cylindrical) tolerance zone to coordinate tolerance zone, the position (cylindrical) tolerance is multiplied by 0.7 (70%). The total coordinate tolerance zone is then divided by 2 to obtain the bilateral tolerance zone.

Figure 5-33 visually demonstrates the conversion from coordinate tolerance zone to position (cylindrical) tolerance zone.

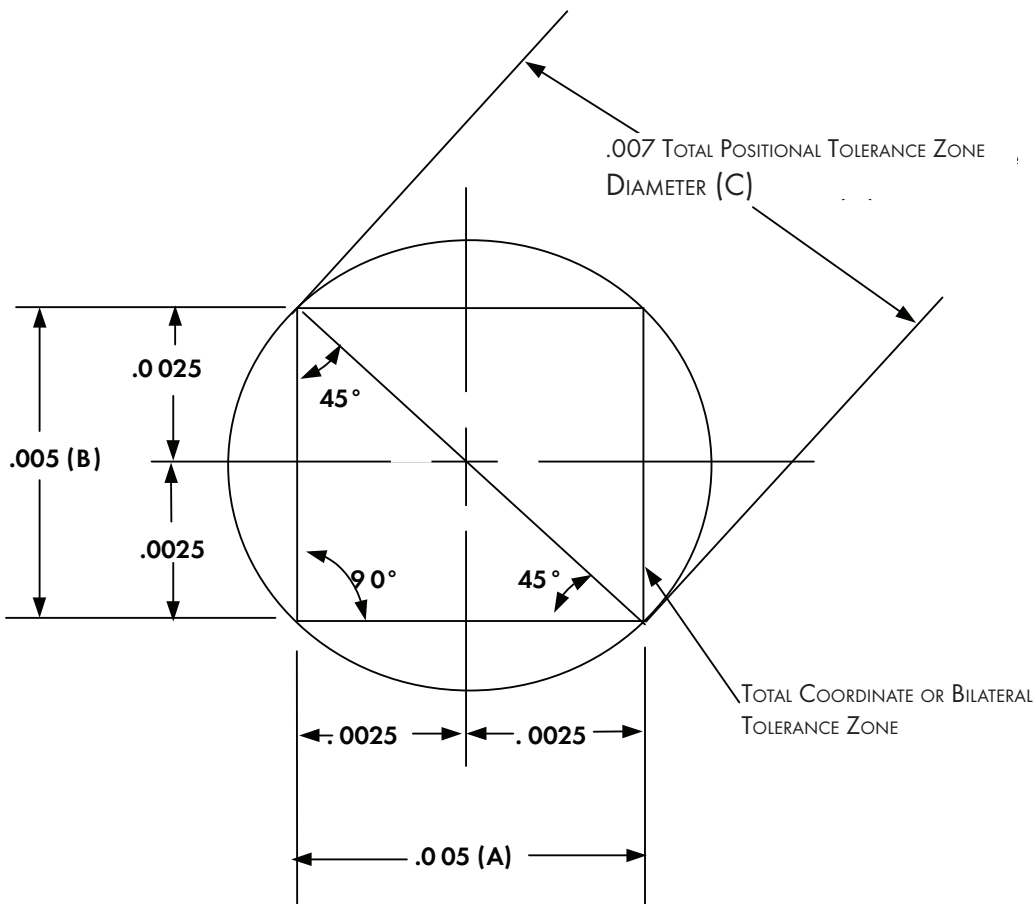

Figure 5-33 Conversion of positional (cylindrical) tolerance zones to/from coordinate tolerance zones.

# Engineering & Design: Geometric Dimensioning

COORDINATE TOL TO  $\oplus$  POSITION TOL

X COORDINATE

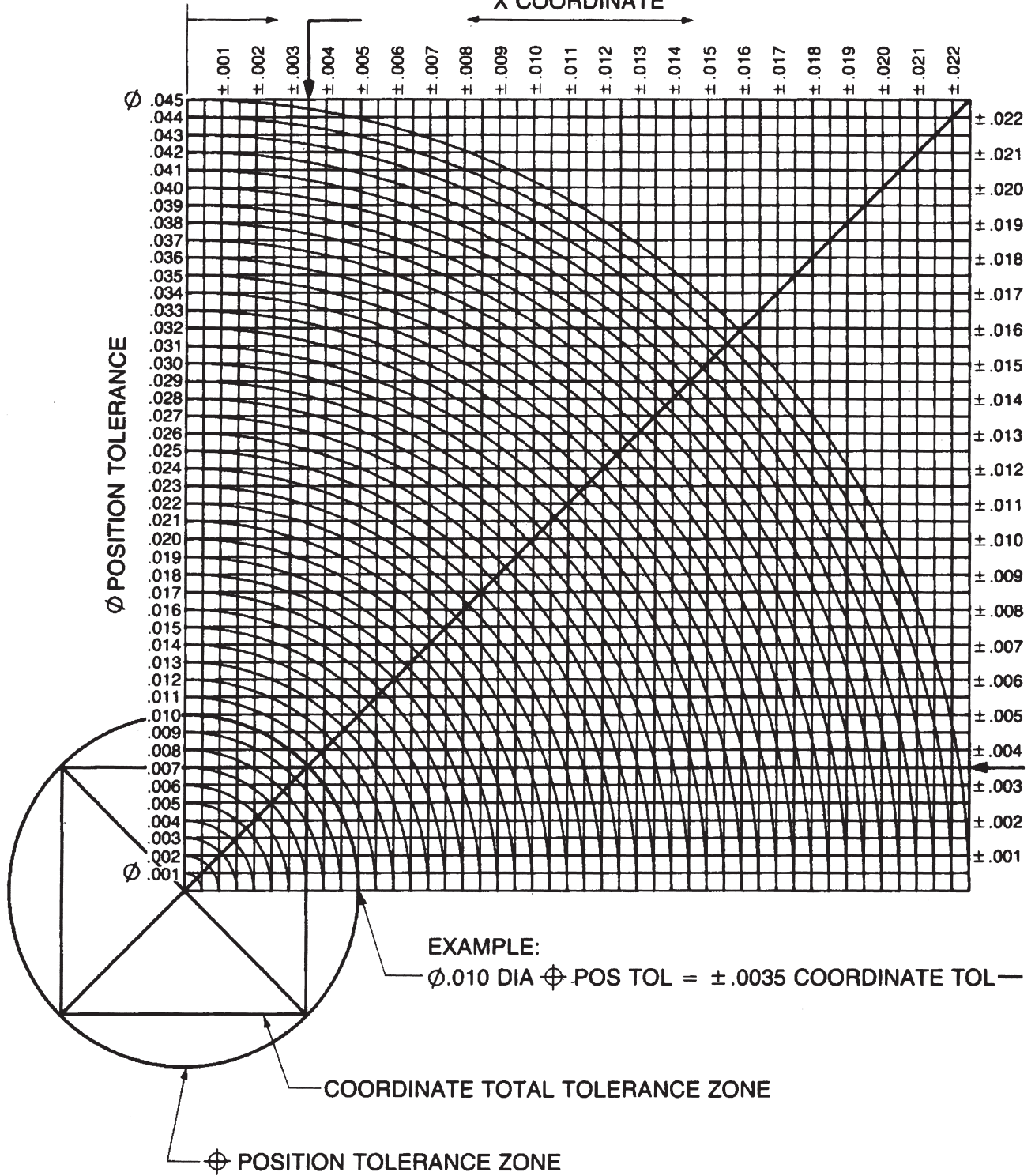

Figure 5-34 Conversions chart for converting between position tolerance and coordinate tolerance.

# Engineering & Design: Geometric Dimensioning

$$\text{Total Coordinate Tolerance Zone} = [\text{Total Position (Cylindrical) Tolerance Zone}] \times [0.7]$$

$$\text{Example: Bilateral Tolerance Zone} = [\text{Total Coordinate Tolerance Zone}] / 2$$

Sometimes parts require a more precise conversion. When a critical application is required, the conversion factor is 0.70711. The position tolerance will be multiplied by 0.70711 (70.711%) to obtain the total coordinate tolerance.

$$\text{Total Coordinate Tol. Zone} = [\text{Total Position (Cylindrical) Tol. Zone}] \times [0.70711]$$

$$\text{Bilateral Tolerance Zone} = [\text{Total Coordinate Tolerance Zone}] / 2$$

For example, to convert 0.007 total position (cylindrical) tolerance to total coordinate tolerance:

$$\begin{aligned} \text{Total Pos. Tol. Zone} \times \text{Conversion Factor} &= \text{Total Coordinate Tolerance Zone} \\ 0.007 \text{ Tol.} \times 0.70711 &= 0.00495 \sim 0.005 \text{ Tot. Coordinate Tol.} \end{aligned}$$

Or

$$\text{Total Coordinate Tol. Zone} / 2 = \text{Bilateral Tol. Zone } 0.005 / 2 = 0.0025 \text{ Bilateral Tolerance}$$

The following example demonstrates a simple conversion from total position tolerance zone to total coordinate tolerance zone and bilateral tolerance zone. Figure 5-36 visually demonstrates the conversion from position (cylindrical) tolerance zone to the coordinate tolerance zone.

When converting from total coordinate tolerance zone to total position (cylindrical) tolerance zone, the total coordinate tolerance zone is multiplied by 1.4142. A bilateral tolerance zone is multiplied by 2 then multiplied by 1.4142 to obtain the total position (cylindrical) tolerance zone.

For non-critical applications, it is acceptable to multiply the total coordinate tolerance zone by 1.4 to obtain the total position tolerance zone. A bilateral tolerance may be multiplied by 2 to obtain the total coordinate tolerance zone, then multiplied by 1.4 to get the total position tolerance zone.

$$\text{Total Position Tol. Zone} = [\text{Total Coordinate Tol. Zone}] \times [1.4142]$$

$$\text{Total Position Tol. Zone} = [\text{Bilateral Tol. Zone}] \times [2] \times [1.4142]$$

For example, to convert .005 total coordinate tolerance to total position (cylindrical) tolerance:

$$\begin{aligned} [\text{Total Coordinate Tolerance Zone}] \times [\text{Conversion Factor}] &= \text{Total Position Tol. Zone} \\ [0.005 \text{ Total Coordinate Tol. Zone}] \times [1.4142] &= 0.007 \text{ Total Tol. Zone} \end{aligned}$$

Or

$$\begin{aligned} [\text{Bilateral Tolerance Zone}] \times [2] \times [\text{Conversion Factor}] &= \text{Total Position Tol. Zone} \\ [0.0025 \text{ Bilateral Tol.}] \times [2] \times [1.4142] &= 0.007 \text{ Total Tol. Zone} \end{aligned}$$

## 14.2 Conversion of Position Tolerance Zone to/from Coordinate Tolerance Zone

Figure 5-34 is a chart for converting position tolerance zones to coordinate tolerance zones, and for converting coordinate tolerance zones to position tolerance zones.

When looking at the conversion chart in Fig. 5-34, coordinate tolerance zones are listed across the top of the grid and increasing from left to right, and on the right side of the grid increasing from bottom to top. The position tolerances are listed on the left side of the grid and increase from bottom to top. The position tolerances, however, follow the arced line across the grid. The diameter of a position tolerance is given on the drawings, however, the diameter of a coordinate tolerance is given by the length of the diagonal line. A diagonal line is drawn from the lower left corner of the grid at a 45° angle to the upper right corner of the chart. The diameter is calculated by using  $A^2 + B^2 = C^2$ . In figure 5-33, A is the total length of the horizontal line at the bottom and connected to the circle, squared, plus B, the square of the vertical line at the left or right edge and connected to the circle. Take the square root of the sum of the two sides will equal the diameter C.

For example, suppose one wanted to convert a 0.010 diameter position tolerance to a coordinate tolerance. While looking at the chart in Fig. 5-34, begin at the 0.01 position tolerance on the left side of the chart. Follow the corresponding arced line until it crosses the diagonal line on the chart. Where the arced line and the diagonal line intersect, follow the horizontal line across to the right side of the chart. The number on the right side of the chart that corresponds with the horizontal line will give the appropriate bilateral coordinate tolerance. In this example, the corresponding bilateral tolerance is  $\pm 0.0035$ . To quickly verify this conversion, use the multipliers identified in on page 5-31. Multiplying the coordinate tolerance by 0.7 will yield the total coordinate tolerance. This number is then divided by 2 to obtain the bilateral coordinate tolerance.

$$\begin{aligned} & \text{Position Tolerance} = 0.010 \\ & \text{Total Coordinate tolerance} = \text{Position Tol.} \times \text{Conversion Factor} = [0.010] \times [0.7] = 0.007 \\ & \text{Bilateral Tolerance Zone} = \text{Total Coordinate Tolerance} / 2 = [0.007] / [2] = \pm 0.0035 \end{aligned}$$

$$\begin{aligned} & \text{Bilateral Position Tol.} = \pm 0.0035 \\ & \text{Total Position Tol.} = \text{Bilateral Position Tol.} \times 2 = [0.0035] \times [2] = 0.007 \\ & \text{Position Tol.} \times \text{Conv. Factor} = [0.007] \times [1.4] \sim 0.01 \end{aligned}$$

The number obtained from the conversion chart and the number obtained by using the multiplier should be approximately the same.

Suppose it was desired to convert a coordinate tolerance such as 0.007 to a position tolerance. In order to use the conversion chart in Fig. 5-34, the coordinate tolerance must be in bilateral coordinates, so 0.007 is divided by 2. This yields a bilateral coordinate tolerance of  $\pm 0.0035$ . Next, the number .0035 is located on the left side of the conversion chart. Follow the corresponding horizontal line across to the left until it intersects the diagonal line. At this intersection, follow the intersecting arced line all the way across and to the left. The number corresponding to that arced line on the left of the chart gives the associated position tolerance. If done correctly, the position tolerance identified on the chart should be 0.010. This can be double-checked by using the multipliers on page 5-31.

The number obtained from the conversion chart and the number obtained by using the multiplier should be approximately the same.

To convert between position tolerancing and coordinate tolerance, either the conversion table identified in Fig. 5-34, or the multiplication factor identified on page 5-31 may be used.



# Engineering & Design: Geometric Dimensioning

.020	.0400	.0402	.0404	.0408	.0412	.0418	.0424	.0431	.0439	.0447	.0456	.0466	.0477	.0488	.0500	.0512	.0525	.0538	.0552	.0566
.019	.0380	.0382	.0385	.0388	.0393	.0398	.0405	.0412	.0420	.0429	.0439	.0449	.0460	.0472	.0484	.0497	.0510	.0523	.0537	.0552
.018	.0360	.0362	.0365	.0369	.0374	.0379	.0386	.0394	.0403	.0412	.0422	.0433	.0444	.0456	.0469	.0482	.0495	.0509	.0523	.0538
.017	.0340	.0342	.0345	.0349	.0354	.0360	.0368	.0376	.0385	.0394	.0405	.0416	.0428	.0440	.0453	.0467	.0481	.0495	.0510	.0525
.016	.0321	.0322	.0325	.0330	.0335	.0342	.0349	.0358	.0367	.0377	.0388	.0400	.0412	.0425	.0439	.0452	.0467	.0482	.0497	.0512
.015	.0301	.0303	.0306	.0310	.0316	.0323	.0331	.0340	.0350	.0360	.0372	.0384	.0397	.0410	.0424	.0439	.0453	.0469	.0484	.0500
.014	.0281	.0283	.0286	.0291	.0297	.0305	.0313	.0322	.0333	.0344	.0356	.0369	.0382	.0396	.0410	.0425	.0440	.0456	.0472	.0488
.013	.0261	.0263	.0267	.0272	.0278	.0286	.0295	.0305	.0316	.0328	.0340	.0354	.0368	.0382	.0397	.0412	.0428	.0444	.0460	.0477
.012	.0241	.0243	.0247	.0253	.0260	.0268	.0278	.0288	.0300	.0312	.0325	.0339	.0354	.0369	.0384	.0400	.0416	.0433	.0449	.0466
.011	.0221	.0224	.0228	.0234	.0242	.0250	.0261	.0272	.0284	.0297	.0311	.0325	.0340	.0356	.0372	.0388	.0405	.0422	.0439	.0456
.010	.0201	.0204	.0209	.0215	.0224	.0233	.0244	.0256	.0269	.0283	.0297	.0312	.0328	.0344	.0360	.0377	.0394	.0412	.0429	.0447
.009	.0181	.0184	.0190	.0197	.0206	.0216	.0228	.0241	.0254	.0269	.0284	.0300	.0316	.0333	.0350	.0367	.0385	.0402	.0420	.0439
.008	.0161	.0165	.0171	.0179	.0189	.0200	.0213	.0226	.0241	.0256	.0272	.0288	.0305	.0322	.0340	.0358	.0376	.0394	.0412	.0431
.007	.0141	.0146	.0152	.0161	.0172	.0184	.0198	.0213	.0228	.0244	.0261	.0278	.0295	.0313	.0331	.0349	.0368	.0386	.0405	.0424
.006	.0122	.0126	.0134	.0144	.0156	.0170	.0184	.0200	.0216	.0233	.0250	.0268	.0286	.0305	.0323	.0342	.0360	.0379	.0398	.0418
.005	.0102	.0108	.0117	.0128	.0141	.0156	.0172	.0189	.0206	.0224	.0242	.0260	.0278	.0297	.0316	.0335	.0354	.0374	.0393	.0412
.004	.0082	.0089	.0100	.0113	.0128	.0144	.0161	.0179	.0197	.0215	.0234	.0253	.0272	.0291	.0310	.0330	.0349	.0369	.0388	.0408
.003	.0063	.0072	.0085	.0100	.0117	.0134	.0152	.0171	.0190	.0209	.0228	.0247	.0267	.0286	.0306	.0325	.0345	.0365	.0385	.0404
.002	.0045	.0056	.0072	.0089	.0108	.0126	.0146	.0165	.0184	.0204	.0224	.0243	.0263	.0283	.0303	.0322	.0342	.0362	.0382	.0402
.001	.0028	.0045	.0063	.0082	.0102	.0122	.0141	.0161	.0181	.0201	.0221	.0241	.0261	.0281	.0301	.0321	.0340	.0360	.0380	.0400
	.001	.002	.003	.004	.005	.006	.007	.008	.009	.010	.011	.012	.013	.014	.015	.016	.017	.018	.019	.020

Figure 5-35 Conversions chart for converting between coordinate measurement and position measurement.

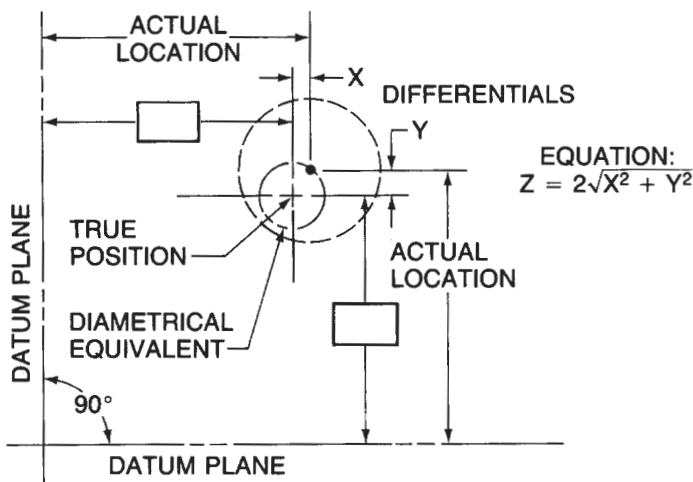

Figure 5-36 Schematic of conversion of coordinate measurements to position location.

## 14.3 Conversion of Coordinate Measurements to Position Location Measurements

In addition to sometimes having to convert between position tolerance zones and coordinate tolerance zones, it is also necessary to convert coordinate measurements to position location measurements. When converting from coordinate measurements to position measurements, the chart identified in Fig. 5-35 is used.

For example, if it was necessary to convert the position measurement 0.0311 to coordinate measurements the following steps need to be accomplished. First, locate the number 0.0311 on the chart in Fig. 5-35. Once the number is located, follow the vertical column down to the X-axis of the chart. The number identified at the very bottom of the column is the X-coordinate measurement. In this example, the X-coordinate is 0.011. Now, relocate the number 0.0311 on the chart and follow the horizontal row to the right until it crosses the Y-axis. The number on the very left end of that row is the Y-coordinate measurement. In this example, the Y-coordinate is 0.011. Since position measurements are three-dimensional, a Z-coordinate must

---

# Engineering & Design: Geometric Dimensioning

also be identified. To find the corresponding Z-coordinate measurement, a simple equation must be performed. This equation is as follows:

$$Z = 2\sqrt{X^2 + Y^2}$$

For this example, Z = 2 times the square root of X squared plus Y squared.

$$Z = 2\sqrt{(0.011)^2 + (0.011)^2}$$

$$Z = 2\sqrt{(0.000121) + (0.000121)}$$

$$Z = 2\sqrt{0.000242}$$

$$Z = 2\sqrt{2(0.015556)}$$

$$Z = 0.031112$$

The coordinate measurements that are associated with the 0.0311 position are

$$X = 0.011, Y = 0.011, \text{ and } Z = 0.031112.$$